

SECTION **PWC**

POWER WINDOW CONTROL SYSTEM

A
B
C

CONTENTS

LH&RH FRONT WINDOW ANTI-PINCH	POWER SUPPLY AND GROUND CIRCUIT16	F
BASIC INSPECTION 4	BCM16	
DIAGNOSIS AND REPAIR WORKFLOW 4	BCM : Diagnosis Procedure16	G
Work Flow4	BCM : Special Repair Requirement17	
INSPECTION AND ADJUSTMENT 7	POWER WINDOW MAIN SWITCH17	H
ADDITIONAL SERVICE WHEN REMOVING BATTERY NEGATIVE TERMINAL7	POWER WINDOW MAIN SWITCH : Diagnosis Procedure17	
ADDITIONAL SERVICE WHEN REMOVING BATTERY NEGATIVE TERMINAL : Description7	POWER WINDOW MAIN SWITCH : Special Repair Requirement18	I
ADDITIONAL SERVICE WHEN REMOVING BATTERY NEGATIVE TERMINAL : Special Repair Requirement7	FRONT POWER WINDOW SWITCH18	
ADDITIONAL SERVICE WHEN REPLACING CONTROL UNIT7	FRONT POWER WINDOW SWITCH : Diagnosis Procedure18	J
ADDITIONAL SERVICE WHEN REPLACING CONTROL UNIT : Description7	FRONT POWER WINDOW SWITCH : Special Repair Requirement19	
ADDITIONAL SERVICE WHEN REPLACING CONTROL UNIT : Special Repair Requirement7	REAR POWER WINDOW SWITCH20	PWC
SYSTEM DESCRIPTION 9	REAR POWER WINDOW SWITCH : Diagnosis Procedure20	L
POWER WINDOW SYSTEM 9	REAR POWER WINDOW SWITCH : Special Repair Requirement21	
System Diagram9	REAR POWER WINDOW SWITCH22	M
System Description9	Description22	
Component Parts Location12	Component Function Check22	N
Component Description13	Diagnosis Procedure22	
DIAGNOSIS SYSTEM (BCM)14	Component Inspection23	O
COMMON ITEM 14	Special Repair Requirement24	
COMMON ITEM : CONSULT Function (BCM - COMMON ITEM) 14	POWER WINDOW MOTOR25	P
RETAINED PWR 14	DRIVER SIDE25	
RETAINED PWR : CONSULT Function (BCM - RETAINED PWR) 15	DRIVER SIDE : Description25	O
DTC/CIRCUIT DIAGNOSIS16	DRIVER SIDE : Component Function Check25	
	DRIVER SIDE : Diagnosis Procedure25	P
	DRIVER SIDE : Component Inspection26	
	DRIVER SIDE : Special Repair Requirement26	O
	PASSENGER SIDE27	
	PASSENGER SIDE : Description27	P

PASSENGER SIDE : Component Function Check	FRONT POWER WINDOW SWITCH : Diagnosis
..... 27	Procedure 47
PASSENGER SIDE : Diagnosis Procedure 27	FRONT POWER WINDOW SWITCH : Special
PASSENGER SIDE : Component Inspection 28	Repair Requirement 48
PASSENGER SIDE : Special Repair Requirement	
..... 28	POWER WINDOW LOCK SWITCH 49
REAR LH 29	Component Function Check 49
REAR LH : Description 29	Component Inspection 49
REAR LH : Component Function Check 29	Special Repair Requirement 49
REAR LH : Diagnosis Procedure 29	
REAR LH : Component Inspection 30	ECU DIAGNOSIS INFORMATION 51
REAR RH 30	POWER WINDOW MAIN SWITCH 51
REAR RH : Description 30	Reference Value 51
REAR RH : Component Function Check 30	Fail Safe 52
REAR RH : Diagnosis Procedure 30	
REAR RH : Component Inspection 31	FRONT POWER WINDOW SWITCH 54
ENCODER 33	Reference Value 54
DRIVER SIDE 33	Fail Safe 55
DRIVER SIDE : Description 33	BCM (BODY CONTROL MODULE) 56
DRIVER SIDE : Component Function Check 33	Reference Value 56
DRIVER SIDE : Diagnosis Procedure 33	Terminal Layout 60
DRIVER SIDE : Special Repair Requirement 35	Physical Values 61
PASSENGER SIDE 35	Fail Safe 76
PASSENGER SIDE : Description 36	DTC Inspection Priority Chart 77
PASSENGER SIDE : Component Function Check	DTC Index 78
..... 36	WIRING DIAGRAM 81
PASSENGER SIDE : Diagnosis Procedure 36	POWER WINDOW SYSTEM 81
PASSENGER SIDE : Special Repair Requirement	Wiring Diagram 81
..... 38	SYMPTOM DIAGNOSIS 89
DOOR SWITCH 39	NONE OF THE POWER WINDOWS CAN BE
Description 39	OPERATED USING ANY SWITCH 89
Component Function Check 39	Diagnosis Procedure 89
Diagnosis Procedure 39	
Component Inspection 41	DRIVER SIDE POWER WINDOW ALONE
DOOR KEY CYLINDER SWITCH 42	DOES NOT OPERATE 90
Description 42	Diagnosis Procedure 90
Component Function Check 42	
Diagnosis Procedure 42	FRONT PASSENGER SIDE POWER WIN-
Component Inspection 43	DOW ALONE DOES NOT OPERATE 91
Special Repair Requirement 44	Diagnosis Procedure 91
POWER WINDOW SERIAL LINK 45	REAR LH SIDE POWER WINDOW ALONE
POWER WINDOW MAIN SWITCH 45	DOES NOT OPERATE 92
POWER WINDOW MAIN SWITCH : Description ... 45	Diagnosis Procedure 92
POWER WINDOW MAIN SWITCH : Component	
Function Check 45	REAR RH SIDE POWER WINDOW ALONE
POWER WINDOW MAIN SWITCH : Diagnosis	DOES NOT OPERATE 93
Procedure 45	Diagnosis Procedure 93
POWER WINDOW MAIN SWITCH : Special Re-	
pair Requirement 46	ANTI-PINCH SYSTEM DOES NOT OPERATE
FRONT POWER WINDOW SWITCH 46	NORMALLY (DRIVER SIDE) 94
FRONT POWER WINDOW SWITCH : Descrip-	Diagnosis Procedure 94
tion 47	ANTI-PINCH SYSTEM DOES NOT OPERATE
	NORMALLY (PASSENGER SIDE) 95
	Diagnosis Procedure 95

AUTO OPERATION DOES NOT OPERATE BUT MANUAL OPERATES NORMALLY (DRIVER SIDE)	96	PRECAUTIONS	102	
Diagnosis Procedure	96	Precaution for Supplemental Restraint System (SRS) "AIR BAG" and "SEAT BELT PRE-TENSIONER"	102	A
AUTO OPERATION DOES NOT OPERATE BUT MANUAL OPERATES NORMALLY (PASSENGER SIDE)	97	Precaution for Work	102	B
Diagnosis Procedure	97	PREPARATION	103	
POWER WINDOW RETAINED POWER OPERATION DOES NOT OPERATE PROPERLY	98	PREPARATION	103	C
Diagnosis Procedure	98	Special Service Tool	103	
DOES NOT OPERATE BY KEY CYLINDER SWITCH	99	PERIODIC MAINTENANCE	104	D
Diagnosis Procedure	99	PRE-INSPECTION FOR DIAGNOSTIC	104	
KEYLESS POWER WINDOW DOWN DOES NOT OPERATE	100	Basic Inspection	104	E
Diagnosis Procedure	100	REMOVAL AND INSTALLATION	105	
POWER WINDOW LOCK SWITCH DOES NOT FUNCTION	101	MAIN POWER WINDOW AND DOOR LOCK/UNLOCK SWITCH	105	F
Diagnosis Procedure	101	Removal and Installation	105	
PRECAUTION	102	POWER WINDOW AND DOOR LOCK/UNLOCK SWITCH RH	106	G
		Removal and Installation	106	
		REAR POWER WINDOW SWITCH	107	H
		Removal and Installation	107	
				I
				J
				L
				M
				N
				O
				P

PWC

DIAGNOSIS AND REPAIR WORKFLOW

< BASIC INSPECTION >

[LH&RH FRONT WINDOW ANTI-PINCH]

BASIC INSPECTION

DIAGNOSIS AND REPAIR WORKFLOW

Work Flow

INFOID:000000007253462

OVERALL SEQUENCE

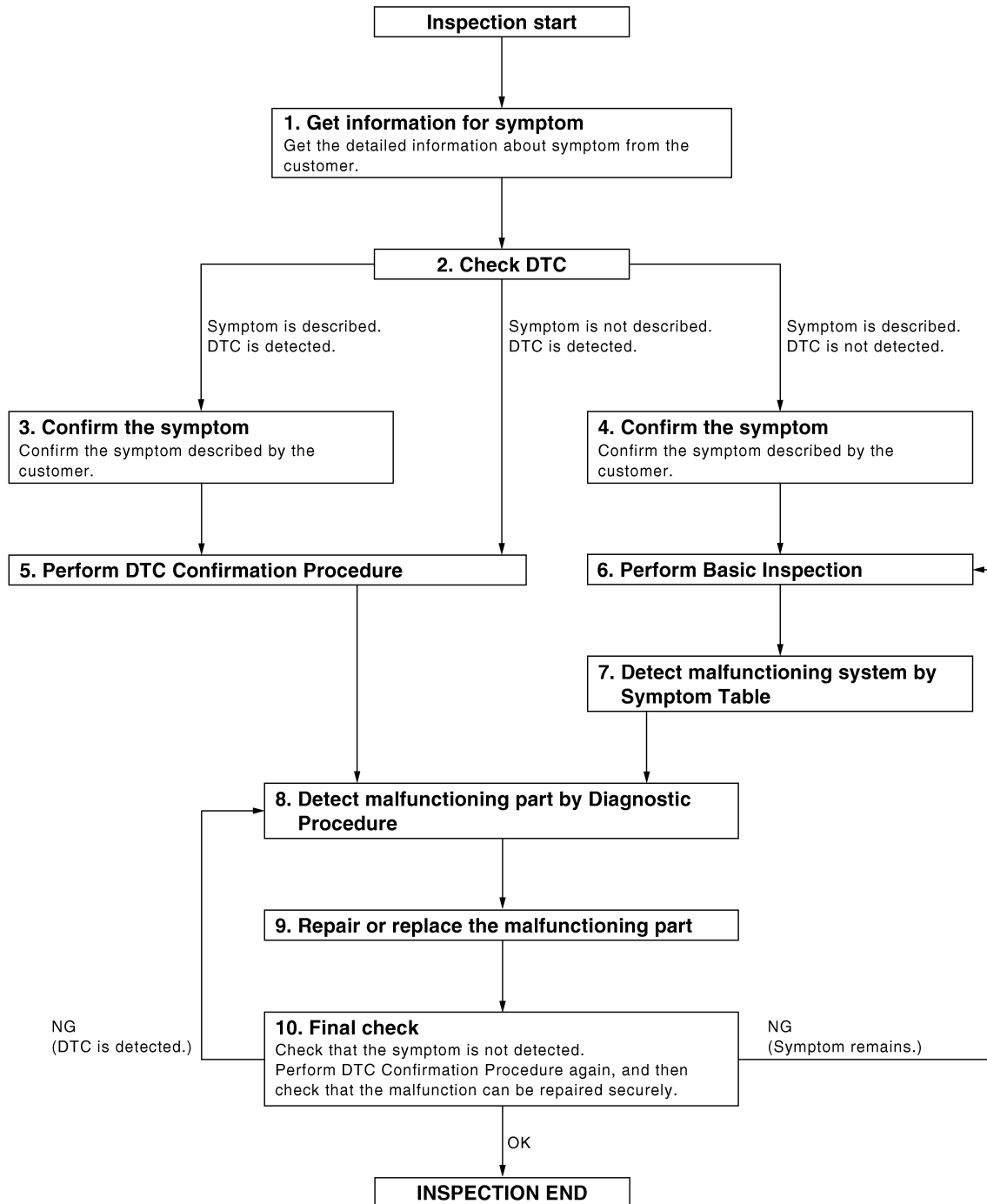

DETAILED FLOW

Revision: August 2012

PWC-4

JMKIA0101GB

2012 Maxima

DIAGNOSIS AND REPAIR WORKFLOW

< BASIC INSPECTION >

[LH&RH FRONT WINDOW ANTI-PINCH]

1. GET INFORMATION FOR SYMPTOM

Get the detailed information from the customer about the symptom (the condition and the environment when the incident/malfunction occurred).

>> GO TO 2

2. CHECK DTC

1. Check DTC.
2. Perform the following procedure if DTC is displayed.
 - Record DTC and freeze frame data (Print them out with CONSULT.)
 - Erase DTC.
 - Study the relationship between the cause detected by DTC and the symptom described by the customer.
3. Check related service bulletins for information.

Is any symptom described and any DTC detected?

Symptom is described, DTC is displayed>>GO TO 3

Symptom is described, DTC is not displayed>>GO TO 4

Symptom is not described, DTC is displayed>>GO TO 5

3. CONFIRM THE SYMPTOM

Confirm the symptom described by the customer.

Connect CONSULT to the vehicle in "DATA MONITOR" mode and check real time diagnosis results. Verify relation between the symptom and the condition when the symptom is detected.

>> GO TO 5

4. CONFIRM THE SYMPTOM

Confirm the symptom described by the customer.

Connect CONSULT to the vehicle in "DATA MONITOR" mode and check real time diagnosis results. Verify relation between the symptom and the condition when the symptom is detected.

>> GO TO 6

5. PERFORM DTC CONFIRMATION PROCEDURE

Perform DTC Confirmation Procedure for the displayed DTC, and then check that DTC is detected again. At this time, always connect CONSULT to the vehicle, and check diagnostic results in real time.

If two or more DTCs are detected, refer to [BCS-64. "DTC Inspection Priority Chart"](#) and determine trouble diagnosis order.

NOTE:

- Freeze frame data is useful if the DTC is not detected.
- Perform Component Function Check if DTC Confirmation Procedure is not included in Service Manual. This simplified check procedure is an effective alternative though DTC cannot be detected during this check. If the result of Component Function Check is NG, it is the same as the detection of DTC by DTC Confirmation Procedure.

Is DTC detected?

YES >> GO TO 8

NO >> Refer to [GI-39. "Intermittent Incident"](#).

6. PERFORM BASIC INSPECTION

Perform [PWC-4. "Work Flow"](#).

Inspection End>>GO TO 7

7. DETECT MALFUNCTIONING SYSTEM BY SYMPTOM TABLE

Detect malfunctioning system based on the confirmed symptom in step 4, and determine the trouble diagnosis order based on possible causes and symptom.

>> GO TO 8

A
B
C
D
E
F
G
H
I
J
L
M
N
O
P

PWC

DIAGNOSIS AND REPAIR WORKFLOW

< BASIC INSPECTION >

[LH&RH FRONT WINDOW ANTI-PINCH]

8. DETECT MALFUNCTIONING PART BY DIAGNOSTIC PROCEDURE

Inspect according to Diagnostic Procedure of the system.

NOTE:

The Diagnostic Procedure described based on open circuit inspection. A short circuit inspection is also required for the circuit check in the Diagnostic Procedure.

Is malfunctioning part detected?

YES >> GO TO 9

NO >> Check voltage of related BCM terminals using CONSULT.

9. REPAIR OR REPLACE THE MALFUNCTIONING PART

1. Repair or replace the malfunctioning part.
2. Reconnect parts or connectors disconnected during Diagnostic Procedure again after repair and replacement.
3. Check DTC. If DTC is displayed, erase it.

>> GO TO 10

10. FINAL CHECK

When DTC was detected in step 2, perform DTC Confirmation Procedure or Component Function Check again, and then check that the malfunction has been repaired securely.

When symptom was described from the customer, refer to confirmed symptom in step 3 or 4, and check that the symptom is not detected.

Does the symptom reappear?

YES (DTC is detected)>>GO TO 8

YES (Symptom remains)>>GO TO 6

NO >> Inspection End.

INSPECTION AND ADJUSTMENT

< BASIC INSPECTION >

[LH&RH FRONT WINDOW ANTI-PINCH]

INSPECTION AND ADJUSTMENT

ADDITIONAL SERVICE WHEN REMOVING BATTERY NEGATIVE TERMINAL

ADDITIONAL SERVICE WHEN REMOVING BATTERY NEGATIVE TERMINAL : Description

INFOID:000000007253463

Initial setting is necessary when battery terminal is removed.

CAUTION:

The following specified operations are not performed under the non-initialized condition.

- Auto-up operation
- Anti-pinch function
- Retained power operation

ADDITIONAL SERVICE WHEN REMOVING BATTERY NEGATIVE TERMINAL : Special Repair Requirement

INFOID:000000007253464

INITIALIZATION PROCEDURE

1. Disconnect battery negative terminal or power window main switch connector. Reconnect it after a minute or more.
2. Turn ignition switch ON.
3. Operate power window switch to fully open the window. (This operation is unnecessary if the window is already fully open)
4. Continue pulling the power window switch UP (AUTO-UP operation). Even after glass stops at fully closed position, keep pulling the switch for 4 seconds or more.
5. Inspect anti-pinch function.

CHECK ANTI-PINCH FUNCTION

1. Fully open the door window.
2. Place a piece of wood near fully closed position.
3. Close door glass completely with AUTO-UP.
 - Check that glass lowers for approximately 150 mm (5.91 in) or 2 seconds without pinching piece of wood and stops.
 - Check that glass does not rise when operating the power window main switch while lowering.

CAUTION:

- Do not check with hands and other parts of the body because they may be pinched. Do not get pinched.
 - Check that AUTO-UP operates before inspection when system initialization is performed.
 - It may switch to fail-safe mode if open/close operation is performed continuously. Perform initial setting in that situation. Refer to [PWC-52, "Fail Safe"](#).
 - Perform initial setting when auto-up operation or anti-pinch function does not operate normally.
 - Finish initial setting. Otherwise, next operation cannot be done.
1. Auto-up operation
 2. Anti-pinch function
 3. Retained power operation when ignition switch is OFF.

ADDITIONAL SERVICE WHEN REPLACING CONTROL UNIT

ADDITIONAL SERVICE WHEN REPLACING CONTROL UNIT : Description

INFOID:000000007253465

Initial setting is necessary when replacing power window main switch.

CAUTION:

The following specified operations are not performed under the non-initialized condition.

- Auto-up operation
- Anti-pinch function
- Retained power operation

ADDITIONAL SERVICE WHEN REPLACING CONTROL UNIT : Special Repair Requirement

INFOID:000000007253466

INITIALIZATION PROCEDURE

A
B
C
D
E
F
G
H
I
J
L
M
N
O
P

PWC

INSPECTION AND ADJUSTMENT

< BASIC INSPECTION >

[LH&RH FRONT WINDOW ANTI-PINCH]

1. Disconnect battery negative terminal or power window main switch connector. Reconnect it after a minute or more.
2. Turn ignition switch ON.
3. Operate power window switch to fully open the window. (This operation is unnecessary if the window is already fully open)
4. Continue pulling the power window switch UP (AUTO-UP operation). Even after glass stops at fully closed position, keep pulling the switch for 4 seconds or more.
5. Inspect anti-pinch function.

CHECK ANTI-PINCH FUNCTION

1. Fully open the door window.
2. Place a piece of wood near fully closed position.
3. Close door glass completely with AUTO-UP.
 - Check that glass lowers for approximately 150 mm (5.91 in) or 2 seconds without pinching piece of wood and stops.
 - Check that glass does not rise when operating the power window main switch while lowering.

CAUTION:

- **Do not check with hands and other parts of the body because they may be pinched. Do not get pinched.**
 - **Check that AUTO-UP operates before inspection when system initialization is performed.**
 - **It may switch to fail-safe mode if open/close operation is performed continuously. Perform initial setting in that situation. Refer to [PWC-52, "Fail Safe"](#).**
 - **Perform initial setting when auto-up operation or anti-pinch function does not operate normally.**
 - **Finish initial setting. Otherwise, next operation cannot be done.**
1. Auto-up operation
 2. Anti-pinch function
 3. Retained power operation when ignition switch is OFF.

POWER WINDOW SYSTEM

< SYSTEM DESCRIPTION >

[LH&RH FRONT WINDOW ANTI-PINCH]

SYSTEM DESCRIPTION

POWER WINDOW SYSTEM

System Diagram

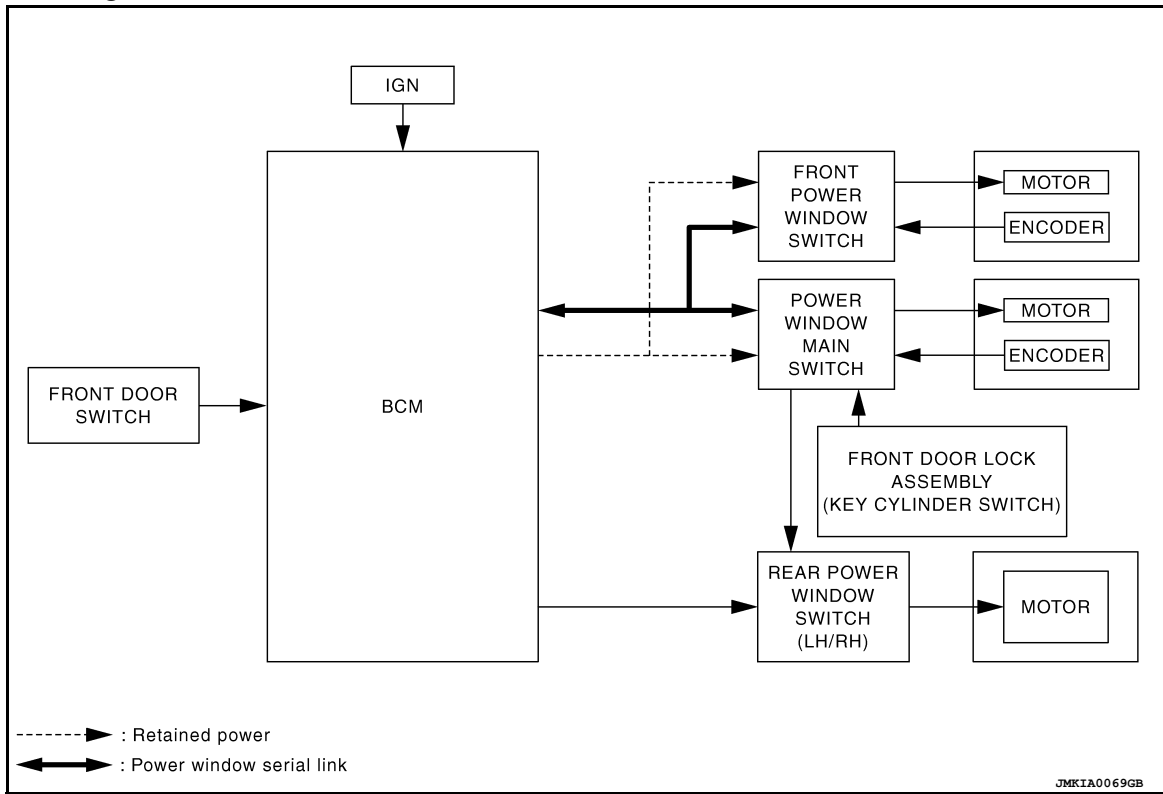

System Description

INFOID:000000007253468

POWER WINDOW MAIN SWITCH INPUT/OUTPUT SIGNAL CHART

PWC

Item	Input signal to power window main switch	Power window main switch function	Actuator
Key cylinder switch	LOCK/UNLOCK signal (more than 1 second over)	Power window control	Front power window motor
Encoder	Encoder pulse signal		
Power window main switch	Front power window motor (driver side) UP/DOWN signal		
Front power window switch (passenger side)	Front power window motor (passenger side) UP/DOWN signal		
BCM	RAP signal		
Rear power window switch	Rear power window motor UP/DOWN signal		Rear power window motor

FRONT POWER WINDOW SWITCH INPUT/OUTPUT SIGNAL CHART

POWER WINDOW SYSTEM

< SYSTEM DESCRIPTION >

[LH&RH FRONT WINDOW ANTI-PINCH]

Item	Input signal to front power window switch	Front power window switch function	Actuator
Front power window switch (passenger side)	Front power window motor (passenger side) UP/DOWN signal	Power window control	Front power window motor (passenger side)
Encoder	Encoder pulse signal		
BCM	RAP signal		

POWER WINDOW OPERATION

- Power window system is operable during the retained power operation timer after turning ignition switch ON and OFF.
- Power window main switch (driver side) can open/close all windows.
- Front & rear power window switch can open/close the corresponding windows.

POWER WINDOW AUTO-OPERATION (FRONT DRIVER SIDE & PASSENGER SIDE)

- AUTO UP/DOWN operation can be performed when power window main switch & front power window switch (passenger side) turns to AUTO.
- Encoder continues detecting the movement of power window motor and transmits to power window switch as the encoder pulse signal while power window motor is operating.
- Power window switch reads the changes of encoder signal and stops AUTO operation when door glass is at fully opened/closed position.
- Power window motor is operable in case encoder is malfunctioning.

RETAINED POWER OPERATION

- Retained power operation is an additional power supply function that enables power window system to operate during the 45 seconds even when ignition switch is turned OFF.

Retained power function cancel conditions

- Front door CLOSE (door switch OFF)→OPEN (door switch ON).
- When ignition switch is ON.
- When timer time passes. (45 seconds)

POWER WINDOW LOCK

Ground circuit inside power window main switch shuts off when power window lock switch is ON. This inhibits power window switch operation except with the power window switch.

ANTI-PINCH OPERATION (FRONT DRIVER SIDE & PASSENGER SIDE)

- Pinch foreign material in the door glass during AUTO-UP operation, and it is the anti-pinch function that lowers the door glass 150 mm (5.91 in) or 2 seconds when detected.
- Encoder continues detecting the movement of power window motor and transmits to power window switch as the encoder pulse signal while power window motor is operating.
- Resistance is applied to the power window motor rotation that changes the frequency of encoder pulse signal if foreign material is trapped in the door glass.
- Power window switch controls to lower the window glass for 150 mm or 2 seconds after it detects encoder pulse signal frequency change.

OPERATION CONDITION

- When all door glass AUTO-UP operation is performed (anti-pinch function does not operate just before the door glass closes and is fully closed).

NOTE:

Depending on environment and driving conditions, if a similar impact or load is applied to the door glass, it may lower.

KEY CYLINDER SWITCH OPERATION

Hold the door key cylinder to the LOCK or UNLOCK direction for 1 second or more to OPEN or CLOSE front power windows when ignition switch is OFF. In addition, it stops when key position is moved to NEUTRAL when operating.

OPERATION CONDITION

- Ignition switch OFF.
- Hold door key cylinder to LOCK position for 1 second or more to perform CLOSE operation of the door glass.

POWER WINDOW SYSTEM

< SYSTEM DESCRIPTION >

[LH&RH FRONT WINDOW ANTI-PINCH]

- Hold door key cylinder to UNLOCK position for 1 second or more to perform OPEN operation of the door glass.

KEYLESS POWER WINDOW DOWN OPERATION (FRONT DRIVER SIDE & PASSENGER SIDE)

All power windows open when the unlock button on Intelligent Key is activated and kept pressed for more than 3 seconds^{NOTE} with the ignition switch OFF. The windows keep opening if the unlock button is continuously pressed.

The power window opening stops when the following operations are performed:

- When the unlock button is kept pressed more than 15 seconds.
- When the ignition switch is turned ON while the power window opening is operated.
- When the unlock button is released.

While retained power operation is active, keyless power window down function cannot be operated.

Keyless power window down operation mode can be changed by "PW DOWN SET" mode in "WORK SUPPORT". Refer to [BCS-24. "INTELLIGENT KEY : CONSULT Function \(BCM - INTELLIGENT KEY\)".](#)

NOTE:

Use CONSULT to change settings.

MODE 1 (3 sec) / MODE 2 (OFF) / MODE 3 (5 sec)

A
B
C
D
E
F
G
H
I
J
L
M
N
O
P

PWC

POWER WINDOW SYSTEM

< SYSTEM DESCRIPTION >

[LH&RH FRONT WINDOW ANTI-PINCH]

Component Parts Location

INFOID:000000007253469

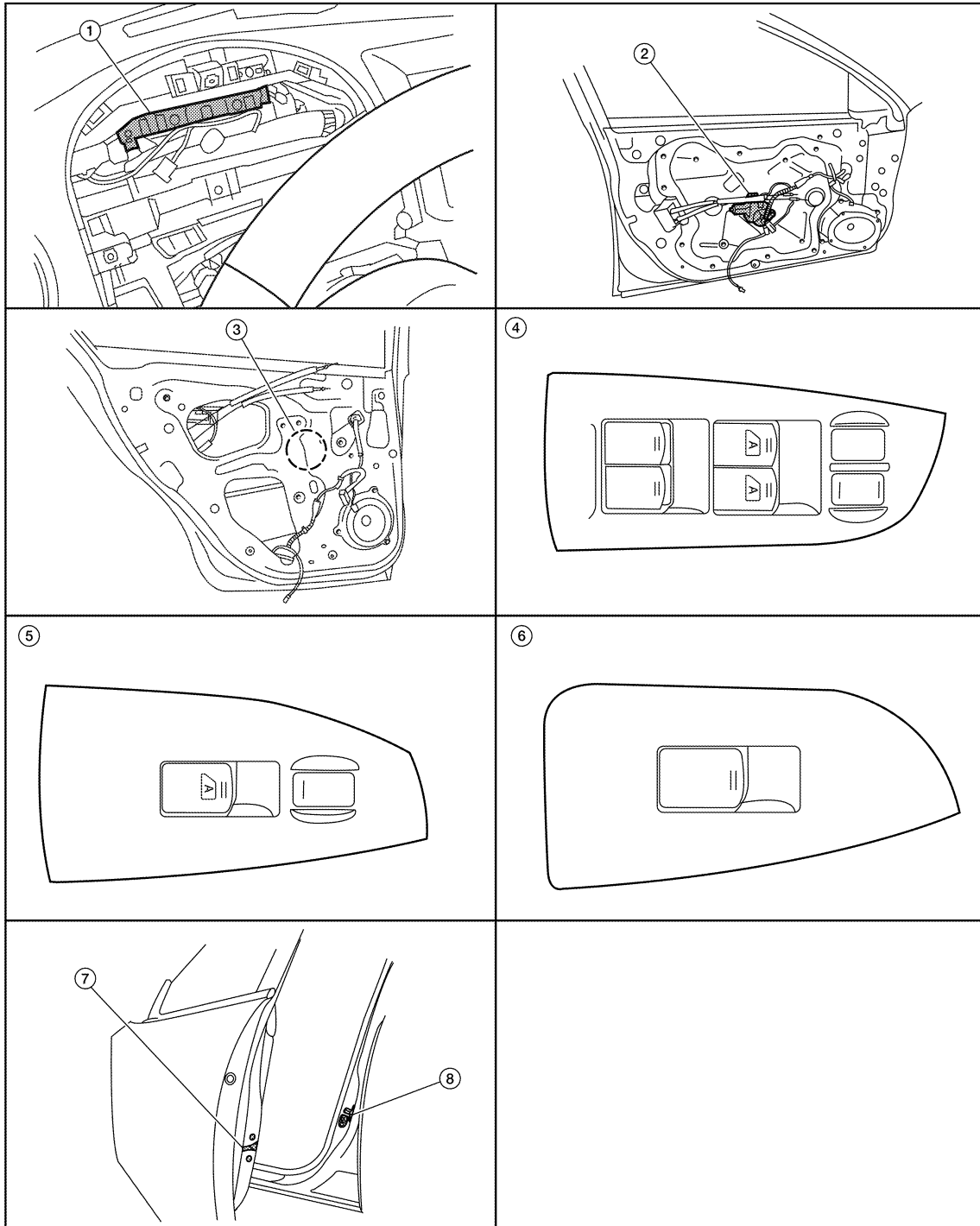

AWK1A1395ZZ

- | | | |
|--|---|---|
| 1. BCM M16, M17, M18 (view with combination meter removed) | 2. Front power window motor LH D9
Front power window motor RH D104 | 3. Rear power window motor LH D204
Rear power window motor RH D304 |
| 4. Main power window and door lock/unlock switch D7, D8 | 5. Power window and door lock/unlock switch RH D105 | 6. Rear power window switch LH D203
Rear power window switch RH D303 |
| 7. Front door lock assembly LH (key cylinder switch) D10 | 8. Front door switch LH B8
Front door switch RH B108 | |

POWER WINDOW SYSTEM

[LH&RH FRONT WINDOW ANTI-PINCH]

< SYSTEM DESCRIPTION >

Component Description

INFOID:000000007253470

Component	Function
BCM	<ul style="list-style-type: none">• Supplies power supply to power window switch.• Controls retained power.
Power window main switch	<ul style="list-style-type: none">• Directly controls all power window motor of all doors.• Controls anti-pinch operation of power window.
Front power window switch	<ul style="list-style-type: none">• Controls power window motor of passenger door.• Controls anti-pinch operation of power window.
Rear power window switch	<ul style="list-style-type: none">• Controls power window motor of rear right and left doors.
Front power window motor	<ul style="list-style-type: none">• Integrates the ENCODER POWER and WINDOW MOTOR.• Starts operating with signals from power window main switch & front power window switch (passenger side).• Transmits power window motor rotation as a pulse signal to power window switch.
Rear power window motor	Starts operating with signals from power window main switch & rear power window switch.
Front door lock assembly (key cylinder switch)	Transmits operation condition of key cylinder switch to power window main switch.
Front door switch	Detects door open/close condition and transmits to BCM.

A
B
C
D
E
F
G
H
I
J
L
M
N
O
P

PWC

DIAGNOSIS SYSTEM (BCM)

[LH&RH FRONT WINDOW ANTI-PINCH]

< SYSTEM DESCRIPTION >

DIAGNOSIS SYSTEM (BCM)

COMMON ITEM

COMMON ITEM : CONSULT Function (BCM - COMMON ITEM)

INFOID:000000007806500

APPLICATION ITEM

CONSULT performs the following functions via CAN communication with BCM.

Direct Diagnostic Mode	Description
Ecu Identification	The BCM part number is displayed.
Self Diagnostic Result	Displays the diagnosis results judged by BCM.
Data Monitor	The BCM input/output signals are displayed.
Active Test	The signals used to activate each device are forcibly supplied from BCM.
Work support	Changes the setting for each system function.
Configuration	<ul style="list-style-type: none"> Enables to read and save the vehicle specification. Enables to write the vehicle specification when replacing BCM.
CAN Diag Support Mntnr	Monitors the reception status of CAN communication viewed from BCM.

SYSTEM APPLICATION

BCM can perform the following functions.

System	Sub System	Direct Diagnostic Mode						
		Ecu Identification	Self Diagnostic Result	Data Monitor	Active Test	Work support	Configuration	CAN Diag Support Mntnr
Door lock	DOOR LOCK		×	×	×	×		
Rear window defogger	REAR DEFOGGER			×	×			
Warning chime	BUZZER			×	×			
Interior room lamp timer	INT LAMP			×	×	×		
Exterior lamp	HEADLAMP			×	×	×		
Wiper and washer	WIPER			×	×	×		
Turn signal and hazard warning lamps	FLASHER			×	×	×		
Intelligent Key system	INTELLIGENT KEY			×	×	×		
Combination switch	COMB SW			×				
BCM	BCM	×	×			×	×	×
Immobilizer	IMMU		×	×	×			
Interior room lamp battery saver	BATTERY SAVER			×	×	×		
Trunk open	TRUNK			×	×			
Vehicle security system	THEFT ALM			×	×	×		
RAP system	RETAINED PWR			×				
Signal buffer system	SIGNAL BUFFER			×	×			
TPMS	AIR PRESSURE MONITOR		×	×	×	×		

RETAINED PWR

DIAGNOSIS SYSTEM (BCM)

< SYSTEM DESCRIPTION >

[LH&RH FRONT WINDOW ANTI-PINCH]

RETAINED PWR : CONSULT Function (BCM - RETAINED PWR)

INFOID:000000007806501

DATA MONITOR

Monitor Item [Unit]	Description
DOOR SW-DR [On/Off]	Indicates condition of front door switch LH
DOOR SW-AS [On/Off]	Indicates condition of front door switch RH

A

B

C

D

E

F

G

H

I

J

PWC

L

M

N

O

P

POWER SUPPLY AND GROUND CIRCUIT

< DTC/CIRCUIT DIAGNOSIS >

[LH&RH FRONT WINDOW ANTI-PINCH]

DTC/CIRCUIT DIAGNOSIS

POWER SUPPLY AND GROUND CIRCUIT

BCM

BCM : Diagnosis Procedure

INFOID:000000007806503

Regarding Wiring Diagram information, refer to [BCS-68, "Wiring Diagram"](#).

1. CHECK FUSE AND FUSIBLE LINK

Check if the following BCM fuses or fusible link are blown.

Terminal No.	Signal name	Fuse and fusible link No.
1	Battery power supply	H
11		10
24		7

Is the fuse or fusible link blown?

- YES >> Replace the blown fuse or fusible link after repairing the affected circuit.
- NO >> GO TO 2

2. CHECK POWER SUPPLY CIRCUIT

1. Turn ignition switch OFF.
2. Disconnect BCM.
3. Check voltage between BCM harness connector and ground.

Terminals		Voltage (Approx.)
(+)	(-)	
BCM		Ground Battery voltage
Connector	Terminal	
M16 (A)	1	
M17 (B)	11	
M18 (C)	24	

Is the measurement normal?

- YES >> GO TO 3
- NO >> Repair or replace harness.

3. CHECK GROUND CIRCUIT

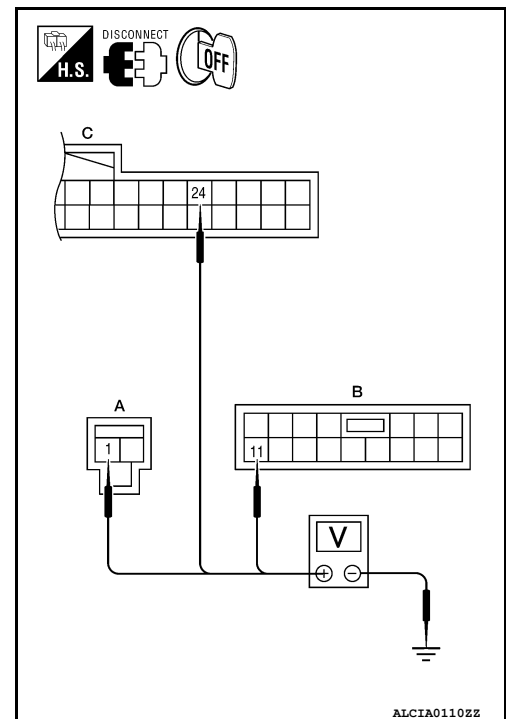

POWER SUPPLY AND GROUND CIRCUIT

< DTC/CIRCUIT DIAGNOSIS >

[LH&RH FRONT WINDOW ANTI-PINCH]

Check continuity between BCM harness connector and ground.

BCM		Ground	Continuity
Connector	Terminal		
M17	13		Yes

Does continuity exist?

- YES >> Inspection End.
- NO >> Repair or replace harness.

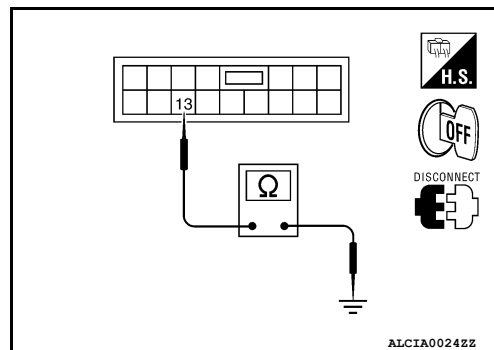

INFOID:000000007806504

BCM : Special Repair Requirement

1. REQUIRED WORK WHEN REPLACING BCM

Initialize control unit. Refer to [BCS-5, "ADDITIONAL SERVICE WHEN REPLACING CONTROL UNIT \(BCM\) : Work Procedure"](#).

>> Work End.

POWER WINDOW MAIN SWITCH

POWER WINDOW MAIN SWITCH : Diagnosis Procedure

INFOID:000000007253475

Regarding Wiring Diagram information, refer to [PWC-81, "Wiring Diagram"](#).

1. CHECK POWER SUPPLY CIRCUIT

1. Turn ignition switch ON.
2. Check voltage between main power window and door lock/unlock switch connectors D7 (A) terminal 10 and D8 (B) terminal 19 and ground.

Terminal (+)		Terminal (-)	Voltage (V) (Approx.)
Main power window and door lock/unlock switch connector	Terminal		
D7 (A)	10	Ground	Battery voltage
D8 (B)	19		

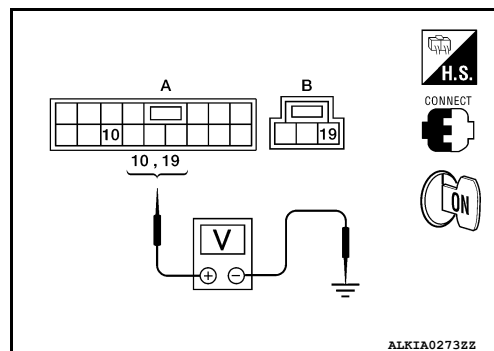

Is the inspection result normal?

- YES >> GO TO 3
- NO >> GO TO 2

2. CHECK HARNESS CONTINUITY

1. Turn ignition switch OFF.
2. Disconnect BCM connector M16 and main power window and door lock/unlock switch connectors.
3. Check continuity between BCM connector M16 (A) terminals 2 and 3 and main power window and door lock/unlock switch connectors D7 (B) terminal 10 and D8 (C) terminal 19.

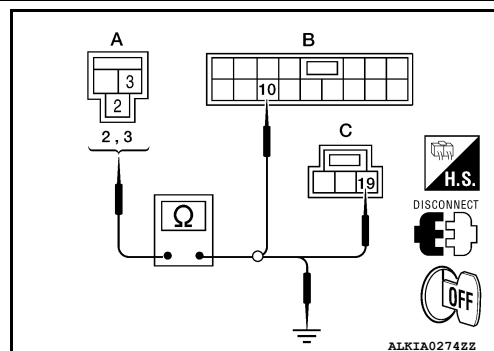

A
B
C
D
E
F
G
H
I
J
PWC
L
M
N
O
P

POWER SUPPLY AND GROUND CIRCUIT

< DTC/CIRCUIT DIAGNOSIS >

[LH&RH FRONT WINDOW ANTI-PINCH]

BCM connector	Terminal	Main power window and door lock/unlock switch connector	Terminal	Continuity
M16 (A)	3	D7 (B)	10	Yes
	2	D8 (C)	19	

4. Check continuity between BCM connector M16 (A) terminals 2 and 3 and ground.

BCM connector	Terminal	Ground	Continuity
M16 (A)	3		
	2		

Is the inspection result normal?

YES >> Replace BCM. Refer to [BCS-80. "Removal and Installation"](#).

NO >> Repair or replace harness or connectors.

3. CHECK GROUND CIRCUIT

1. Turn ignition switch OFF.
2. Disconnect main power window and door lock/unlock switch connector D8.
3. Check continuity between main power window and door lock/unlock switch connector D8 terminal 17 and ground.

Main power window and door lock/unlock switch connector	Terminal	Ground	Continuity
D8	17		

Is the inspection result normal?

YES >> Inspection End.

NO >> Repair or replace harness or connectors.

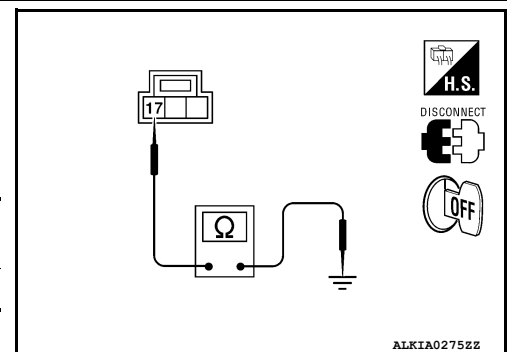

POWER WINDOW MAIN SWITCH : Special Repair Requirement

INFOID:000000007253476

1. PERFORM INITIALIZATION PROCEDURE

Perform initialization procedure. Refer to [PWC-7. "ADDITIONAL SERVICE WHEN REMOVING BATTERY NEGATIVE TERMINAL : Special Repair Requirement"](#) and [PWC-7. "ADDITIONAL SERVICE WHEN REPLACING CONTROL UNIT : Special Repair Requirement"](#).

>> GO TO 2

2. CHECK ANTI-PINCH OPERATION

Check anti-pinch operation. Refer to [PWC-7. "ADDITIONAL SERVICE WHEN REMOVING BATTERY NEGATIVE TERMINAL : Special Repair Requirement"](#) and [PWC-7. "ADDITIONAL SERVICE WHEN REPLACING CONTROL UNIT : Special Repair Requirement"](#).

>> End.

FRONT POWER WINDOW SWITCH

FRONT POWER WINDOW SWITCH : Diagnosis Procedure

INFOID:000000007253477

Regarding Wiring Diagram information, refer to [PWC-81. "Wiring Diagram"](#).

1. CHECK POWER SUPPLY CIRCUIT

POWER SUPPLY AND GROUND CIRCUIT

[LH&RH FRONT WINDOW ANTI-PINCH]

< DTC/CIRCUIT DIAGNOSIS >

Check voltage between power window and door lock/unlock switch RH connector D105 terminal 10 and ground.

Terminal		(-)	Voltage (V) (Approx.)
(+)			
Power window and door lock/unlock switch RH connector	Terminal		
D105	10	Ground	Battery voltage

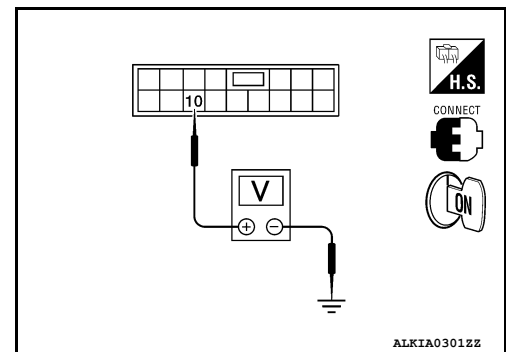

Is the inspection result normal?

- YES >> GO TO 3
- NO >> GO TO 2

2. CHECK HARNESS CONTINUITY

- Turn ignition switch OFF.
- Disconnect BCM connector M16 and power window and door lock/unlock switch RH connector.
- Check continuity between BCM connector M16 (A) terminal 2 and power window and door lock/unlock switch RH connector D105 (B) terminal 10.

BCM connector	Terminal	Power window and door lock/unlock switch RH connector	Terminal	Continuity
M16 (A)	2	D105 (B)	10	Yes

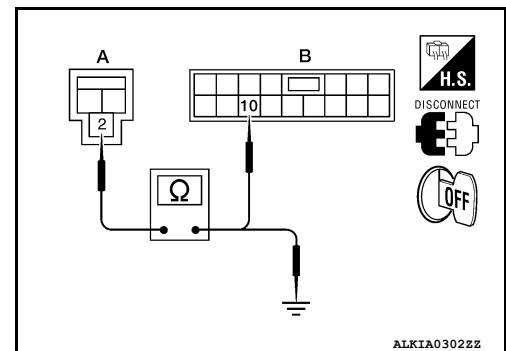

- Check continuity between BCM connector M16 (A) terminal 2 and ground.

BCM connector	Terminal	Ground	Continuity
M16 (A)	2		No

Is the inspection result normal?

- YES >> Replace BCM. Refer to [BCS-80, "Removal and Installation"](#).
- NO >> Repair or replace harness or connectors.

3. CHECK GROUND CIRCUIT

- Turn ignition switch OFF.
- Disconnect power window and door lock/unlock switch RH.
- Check continuity between power window and door lock/unlock switch RH connector D105 terminal 11 and ground.

Power window and door lock/unlock switch RH	Terminal	Ground	Continuity
D105	11		Yes

Is the inspection result normal?

- YES >> Inspection End.
- NO >> Repair or replace harness or connectors.

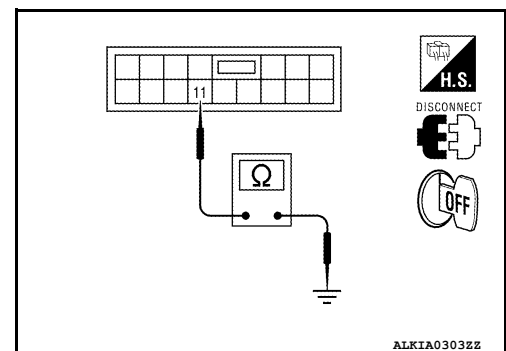

FRONT POWER WINDOW SWITCH : Special Repair Requirement

INFOID:000000007253478

1. PERFORM INITIALIZATION PROCEDURE

Perform initialization procedure. Refer to [PWC-7, "ADDITIONAL SERVICE WHEN REMOVING BATTERY NEGATIVE TERMINAL : Special Repair Requirement"](#) and [PWC-7, "ADDITIONAL SERVICE WHEN REPLACING CONTROL UNIT : Special Repair Requirement"](#).

A
B
C
D
E
F
G
H
I
J
L
M
N
O
P

PWC

POWER SUPPLY AND GROUND CIRCUIT

< DTC/CIRCUIT DIAGNOSIS >

[LH&RH FRONT WINDOW ANTI-PINCH]

>> GO TO 2

2. CHECK ANTI-PINCH OPERATION

Check anti-pinch operation. Refer to [PWC-7, "ADDITIONAL SERVICE WHEN REMOVING BATTERY NEGATIVE TERMINAL : Special Repair Requirement"](#) and [PWC-7, "ADDITIONAL SERVICE WHEN REPLACING CONTROL UNIT : Special Repair Requirement"](#).

>> End.

REAR POWER WINDOW SWITCH

REAR POWER WINDOW SWITCH : Diagnosis Procedure

INFOID:000000007253479

Regarding Wiring Diagram information, refer to [PWC-81, "Wiring Diagram"](#).

1. CHECK POWER SUPPLY CIRCUIT

Check voltage between rear power window switch connector terminal 1 and ground.

Terminal		Terminal	Condition	Voltage (V) (Approx.)
(+)	(-)			
Rear power window switch connector		1	Ignition switch ON	Battery voltage
LH	D203			
RH	D303			

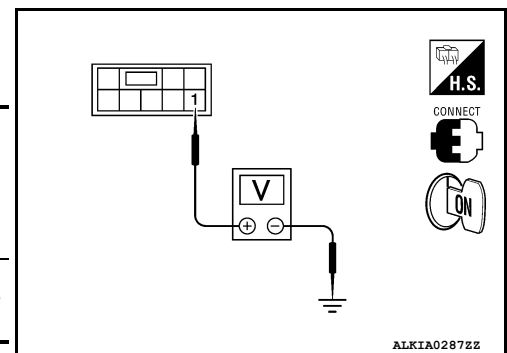

Is the inspection result normal?

YES >> GO TO 3

NO >> GO TO 2

2. CHECK HARNESS CONTINUITY

1. Disconnect BCM connector M16 and rear power window switch connector.
2. Check continuity between BCM connector M16 (A) terminal 3 and rear power window switch connector (B) terminal 1.

BCM connector	Terminal	Rear power window switch connector		Terminal	Continuity
M16 (A)	3	LH	D203 (B)	1	Yes
		RH	D303 (B)		

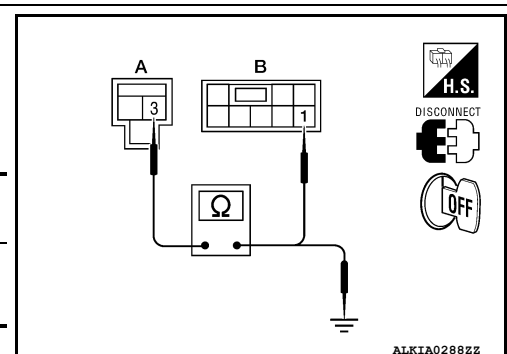

3. Check continuity between BCM connector M16 (A) terminal 3 and ground.

BCM connector	Terminal	Ground	Continuity
M16 (A)	3		No

Is the inspection result normal?

YES >> Replace BCM. Refer to [BCS-80, "Removal and Installation"](#).

NO >> Repair or replace harness or connectors.

3. CHECK GROUND CIRCUIT

POWER SUPPLY AND GROUND CIRCUIT

[LH&RH FRONT WINDOW ANTI-PINCH]

< DTC/CIRCUIT DIAGNOSIS >

1. Disconnect rear power window switch connector.
2. Check continuity between rear power window switch connector terminal 7 and ground.

Rear power window switch connector	Terminal	Ground	Continuity
D203	7	Ground	No
D303			

Is the inspection result normal?

- YES >> Inspection End.
NO >> Repair or replace harness or connectors.

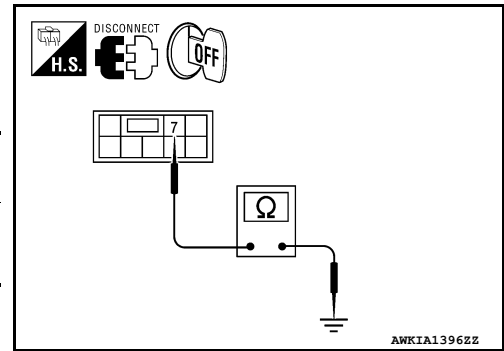

REAR POWER WINDOW SWITCH : Special Repair Requirement

INFOID:000000007253480

1. PERFORM INITIALIZATION PROCEDURE

Perform initialization procedure. Refer to [PWC-7, "ADDITIONAL SERVICE WHEN REMOVING BATTERY NEGATIVE TERMINAL : Special Repair Requirement"](#) and [PWC-7, "ADDITIONAL SERVICE WHEN REPLACING CONTROL UNIT : Special Repair Requirement"](#).

>> GO TO 2

2. CHECK ANTI-PINCH OPERATION

Check anti-pinch operation. Refer to [PWC-7, "ADDITIONAL SERVICE WHEN REMOVING BATTERY NEGATIVE TERMINAL : Special Repair Requirement"](#) and [PWC-7, "ADDITIONAL SERVICE WHEN REPLACING CONTROL UNIT : Special Repair Requirement"](#).

>> End.

A
B
C
D
E
F
G
H
I
J
L
M
N
O
P

PWC

REAR POWER WINDOW SWITCH

< DTC/CIRCUIT DIAGNOSIS >

[LH&RH FRONT WINDOW ANTI-PINCH]

REAR POWER WINDOW SWITCH

Description

INFOID:000000007253481

- BCM supplies power.
- Rear power window motor operates when rear power window switch is activated.

Component Function Check

INFOID:000000007253482

Rear Power Window Switch

1. CHECK REAR POWER WINDOW MOTOR FUNCTION

Check that rear power window motor operates from rear power window switch.

Is the inspection result normal?

- YES >> Rear power window switch is OK.
 NO >> Refer to [PWC-22. "Diagnosis Procedure"](#).

Diagnosis Procedure

INFOID:000000007253483

Regarding Wiring Diagram information, refer to [PWC-81. "Wiring Diagram"](#).

1. CHECK REAR POWER WINDOW SWITCH

Check rear power window switch. Refer to [PWC-23. "Component Inspection"](#).

Is the inspection result normal?

- YES >> GO TO 2
 NO >> Replace rear power window switch. Refer to [PWC-107. "Removal and Installation"](#).

2. CHECK REAR POWER WINDOW SWITCH INPUT SIGNAL

1. Turn ignition switch OFF.
2. Disconnect rear power window switch connector.
3. Turn ignition switch ON.
4. Check voltage between rear power window switch connector and ground.

Rear power window switch		Condition	Voltage (V) (Approx.)	
Connector	Terminal			
D203	2	Power window main switch : LH	UP	Battery voltage
			DOWN	0V
	3	Ground	UP	0V
			DOWN	Battery voltage
D303	2	Power window main switch : RH	UP	Battery voltage
			DOWN	0V
	3	Ground	UP	0V
			DOWN	Battery voltage

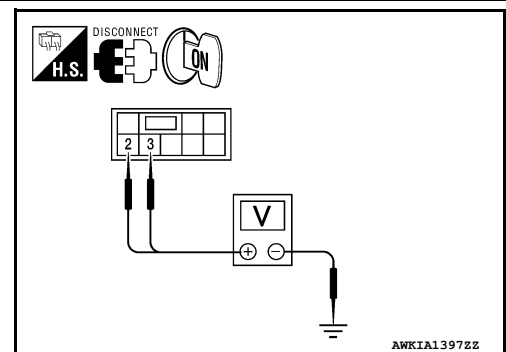

Is the inspection result normal?

- YES >> Check intermittent incident. Refer to [GI-39. "Intermittent Incident"](#).
 NO >> • For rear power window switch LH, GO TO 3
 • For rear power window switch RH, GO TO 4

3. CHECK HARNESS CONTINUITY (REAR POWER WINDOW SWITCH LH)

REAR POWER WINDOW SWITCH

[LH&RH FRONT WINDOW ANTI-PINCH]

< DTC/CIRCUIT DIAGNOSIS >

1. Turn ignition switch OFF.
2. Disconnect main power window and door lock/unlock switch connector D7 and rear power window switch LH connector.
3. Check continuity between main power window and door lock/unlock switch connector D7 (A) terminals 1, 3 and rear power window switch LH connector D203 (B) terminals 2, 3.

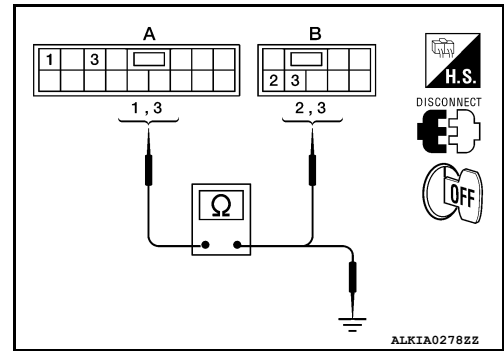

Main power window and door lock/unlock switch connector	Terminal	Rear power window switch LH connector	Terminal	Continuity
D7 (A)	1	D203 (B)	2	Yes
	3		3	

4. Check continuity between main power window and door lock/unlock switch connector D7 (A) terminals 1, 3 and ground.

Main power window and door lock/unlock switch connector	Terminal	Ground	Continuity
D7 (A)	1	Ground	No
	3		

Is the inspection result normal?

YES >> Replace main power window and door lock/unlock switch. Refer to [PWC-105. "Removal and Installation"](#).

NO >> Repair or replace harness or connectors.

4. CHECK HARNESS CONTINUITY (REAR POWER WINDOW SWITCH RH)

1. Turn ignition switch OFF.
2. Disconnect main power window and door lock/unlock switch connector D7 and rear power window switch RH connector.
3. Check continuity between main power window and door lock/unlock switch connector D7 (A) terminals 5, 7 and rear power window switch RH connector D303 (B) terminals 2, 3.

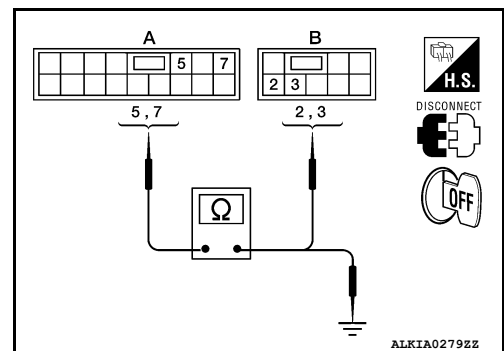

Main power window and door lock/unlock switch connector	Terminal	Rear power window switch RH connector	Terminal	Continuity
D7 (A)	5	D303 (B)	3	Yes
	7		2	

4. Check continuity between main power window and door lock/unlock switch connector D7 (A) terminals 5, 7 and ground.

Main power window and door lock/unlock switch connector	Terminal	Ground	Continuity
D7 (A)	5	Ground	No
	7		

Is the inspection result normal?

YES >> Replace main power window and door lock/unlock switch. Refer to [PWC-105. "Removal and Installation"](#).

NO >> Repair or replace harness or connectors.

Component Inspection

INFOID:000000007253484

COMPONENT INSPECTION

REAR POWER WINDOW SWITCH

< DTC/CIRCUIT DIAGNOSIS >

[LH&RH FRONT WINDOW ANTI-PINCH]

1. CHECK REAR POWER WINDOW SWITCH

Check rear power window switch.

Terminal		Power window switch condition	Continuity
1	5	DOWN	Yes
3	4		
3	4	NEUTRAL	
5	2		
1	4	UP	
5	2		

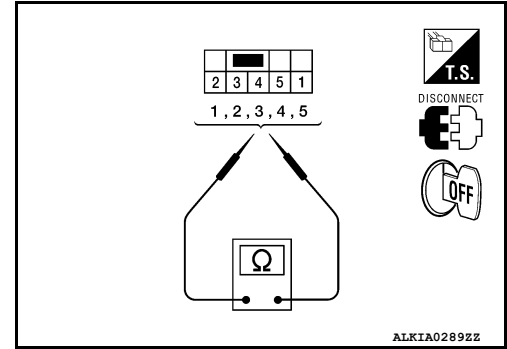

Is the inspection result normal?

YES >> Rear power window switch is OK.

NO >> Replace rear power window switch. Refer to [PWC-107, "Removal and Installation"](#).

Special Repair Requirement

INFOID:000000007253485

1. PERFORM INITIALIZATION PROCEDURE

Perform initialization procedure. Refer to [PWC-7, "ADDITIONAL SERVICE WHEN REMOVING BATTERY NEGATIVE TERMINAL : Special Repair Requirement"](#) and [PWC-7, "ADDITIONAL SERVICE WHEN REPLACING CONTROL UNIT : Special Repair Requirement"](#).

>> GO TO 2

2. CHECK ANTI-PINCH OPERATION

Check anti-pinch operation. Refer to [PWC-7, "ADDITIONAL SERVICE WHEN REMOVING BATTERY NEGATIVE TERMINAL : Special Repair Requirement"](#) and [PWC-7, "ADDITIONAL SERVICE WHEN REPLACING CONTROL UNIT : Special Repair Requirement"](#).

>> End.

POWER WINDOW MOTOR

[LH&RH FRONT WINDOW ANTI-PINCH]

< DTC/CIRCUIT DIAGNOSIS >

POWER WINDOW MOTOR DRIVER SIDE

DRIVER SIDE : Description

INFOID:000000007253486

Door glass moves UP/DOWN by receiving the signal from main power window and door lock/unlock switch.

DRIVER SIDE : Component Function Check

INFOID:000000007253487

1. CHECK POWER WINDOW MOTOR

Check that front power window motor LH operates with main power window and door lock/unlock switch.

Is the inspection result normal?

- YES >> Front power window motor LH is OK.
- NO >> Refer to [PWC-25, "DRIVER SIDE : Diagnosis Procedure"](#).

DRIVER SIDE : Diagnosis Procedure

INFOID:000000007253488

Regarding Wiring Diagram information, refer to [PWC-81, "Wiring Diagram"](#).

1. CHECK POWER WINDOW MOTOR

Check front power window motor LH. Refer to [PWC-26, "DRIVER SIDE : Component Inspection"](#).

Is the inspection result normal?

- YES >> GO TO 2
- NO >> Replace power window motor LH. Refer to [GW-17, "Removal and Installation"](#).

2. CHECK MAIN POWER WINDOW AND DOOR LOCK/UNLOCK SWITCH OUTPUT SIGNAL

1. Disconnect front power window motor LH connector.
2. Turn ignition switch ON.
3. Check voltage between front power window motor LH connector D9 terminals 1, 2 and ground.

Terminal (+)		Terminal (-)	Main power window and door lock/unlock switch condition	Voltage (V) (Approx.)
Power window motor LH connector	Terminal			
D9	2	Ground	UP	Battery voltage
			DOWN	0
	1		UP	0
			DOWN	Battery voltage

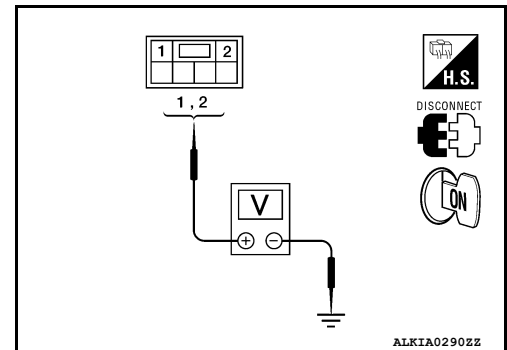

Is the inspection result normal?

- YES >> Check intermittent incident. Refer to [GI-39, "Intermittent Incident"](#).
- NO >> GO TO 3

3. CHECK HARNESS CONTINUITY

POWER WINDOW MOTOR

[LH&RH FRONT WINDOW ANTI-PINCH]

< DTC/CIRCUIT DIAGNOSIS >

1. Turn ignition switch OFF.
2. Disconnect main power window and door lock/unlock switch connector D7.
3. Check continuity between main power window and door lock/unlock switch connector D7 (A) terminals 8, 11 and front power window motor LH connector LH D9 (B) terminals 1, 2.

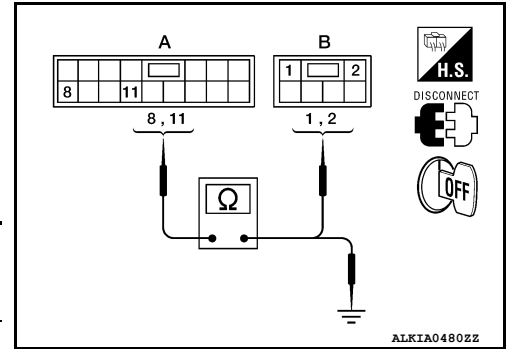

Main power window and door lock/unlock switch connector	Terminal	Front power window motor LH connector	Terminal	Continuity
D7 (A)	8	D9 (B)	2	Yes
	11		1	

4. Check continuity between main power window and door lock/unlock switch connector D7 (A) terminals 8, 11 and ground.

Main power window and door lock/unlock switch connector	Terminal	Ground	Continuity
D7 (A)	8	Ground	No
	11		

Is the inspection result normal?

YES >> Replace main power window and door lock/unlock switch. Refer to [PWC-105, "Removal and Installation"](#).

NO >> Repair or replace harness or connectors.

DRIVER SIDE : Component Inspection

INFOID:000000007253489

COMPONENT INSPECTION

1. CHECK FRONT POWER WINDOW MOTOR LH

1. Disconnect front power window motor LH.
2. Check motor operation by connecting battery voltage directly to front power window motor LH.

Terminal		Motor condition
(+)	(-)	
1	2	DOWN
2	1	UP

Is the inspection result normal?

YES >> Inspection End.

NO >> Replace front power window motor LH. Refer to [GW-17, "Removal and Installation"](#).

DRIVER SIDE : Special Repair Requirement

INFOID:000000007253490

1. PERFORM INITIALIZATION PROCEDURE

Perform initialization procedure. Refer to [PWC-7, "ADDITIONAL SERVICE WHEN REMOVING BATTERY NEGATIVE TERMINAL : Special Repair Requirement"](#) and [PWC-7, "ADDITIONAL SERVICE WHEN REPLACING CONTROL UNIT : Special Repair Requirement"](#).

>> GO TO 2

2. CHECK ANTI-PINCH OPERATION

Check anti-pinch operation. Refer to [PWC-7, "ADDITIONAL SERVICE WHEN REMOVING BATTERY NEGATIVE TERMINAL : Special Repair Requirement"](#) and [PWC-7, "ADDITIONAL SERVICE WHEN REPLACING CONTROL UNIT : Special Repair Requirement"](#).

POWER WINDOW MOTOR

[LH&RH FRONT WINDOW ANTI-PINCH]

< DTC/CIRCUIT DIAGNOSIS >

>> End.

PASSENGER SIDE

PASSENGER SIDE : Description

INFOID:000000007253491

Door glass moves UP/DOWN by receiving the signal from main power window and door lock/unlock switch or power window and door lock/unlock switch RH.

PASSENGER SIDE : Component Function Check

INFOID:000000007253492

1. CHECK POWER WINDOW MOTOR CIRCUIT

Check that front power window motor RH operates with main power window and door lock/unlock switch or power window and door lock/unlock switch RH.

Is the inspection result normal?

YES >> Front power window motor RH is OK.

NO >> Refer to [PWC-27, "PASSENGER SIDE : Diagnosis Procedure"](#).

PASSENGER SIDE : Diagnosis Procedure

INFOID:000000007253493

Regarding Wiring Diagram information, refer to [PWC-81, "Wiring Diagram"](#).

1. CHECK FRONT POWER WINDOW MOTOR RH

Check front power window motor RH. Refer to [PWC-28, "PASSENGER SIDE : Component Inspection"](#).

Is the inspection result normal?

YES >> GO TO 2

NO >> Replace front power window motor RH. Refer to [GW-17, "Removal and Installation"](#).

2. CHECK FRONT POWER WINDOW SWITCH RH OUTPUT SIGNAL

1. Disconnect front power window motor RH connector.
2. Turn ignition switch ON.
3. Check voltage between front power window motor RH connector D104 terminals 1, 2 and ground.

Terminal (+)		Terminal (-)	Front power window motor RH condition	Voltage (V) (Approx.)
Front power window motor RH connector	Terminal			
D104	2	Ground	UP	Battery voltage
			DOWN	0
	1		UP	0
			DOWN	Battery voltage

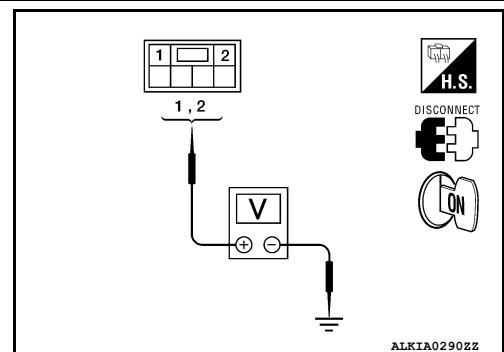

Is the inspection result normal?

YES >> Check intermittent incident. Refer to [GI-39, "Intermittent Incident"](#).

NO >> GO TO 3

3. CHECK HARNESS CONTINUITY

A
B
C
D
E
F
G
H
I
J
L
M
N
O
P

PWC

POWER WINDOW MOTOR

[LH&RH FRONT WINDOW ANTI-PINCH]

< DTC/CIRCUIT DIAGNOSIS >

1. Turn ignition switch OFF.
2. Disconnect power window and door lock/unlock switch RH connector.
3. Check continuity between power window and door lock/unlock switch RH connector D105 (A) terminals 8, 9 and front power window motor RH connector D104 (B) terminals 1, 2.

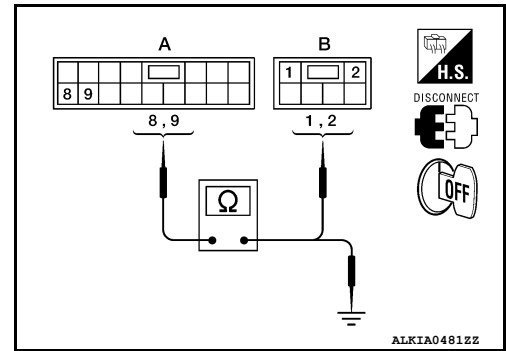

Power window and door lock/unlock switch RH connector	Terminal	Front power window motor RH connector	Terminal	Continuity
D105 (A)	8	D104 (B)	2	Yes
	9		1	

4. Check continuity between power window and door lock/unlock switch RH connector D105 (A) terminals 8, 9 and ground.

Power window and door lock/unlock switch RH connector	Terminal	Ground	Continuity
D105 (A)	8	Ground	No
	9		

Is the inspection result normal?

- YES >> Replace power window and door lock/unlock switch RH. Refer to [PWC-106. "Removal and Installation"](#).
- NO >> Repair or replace harness or connectors.

PASSENGER SIDE : Component Inspection

INFOID:000000007253494

COMPONENT INSPECTION

1. CHECK FRONT POWER WINDOW MOTOR RH

1. Disconnect front power window motor RH.
2. Check motor operation by connecting battery voltage directly to front power window motor RH.

Terminal		Motor condition
(+)	(-)	
1	2	DOWN
2	1	UP

Is the inspection result normal?

- YES >> Inspection End.
- NO >> Replace front power window motor RH. Refer to [GW-17. "Removal and Installation"](#).

PASSENGER SIDE : Special Repair Requirement

INFOID:000000007253495

1. PERFORM INITIALIZATION PROCEDURE

Perform initialization procedure. Refer to [PWC-7. "ADDITIONAL SERVICE WHEN REMOVING BATTERY NEGATIVE TERMINAL : Special Repair Requirement"](#) and [PWC-7. "ADDITIONAL SERVICE WHEN REPLACING CONTROL UNIT : Special Repair Requirement"](#).

>> GO TO 2

2. CHECK ANTI-PINCH OPERATION

Check anti-pinch operation. Refer to [PWC-7. "ADDITIONAL SERVICE WHEN REMOVING BATTERY NEGATIVE TERMINAL : Special Repair Requirement"](#) and [PWC-7. "ADDITIONAL SERVICE WHEN REPLACING CONTROL UNIT : Special Repair Requirement"](#).

POWER WINDOW MOTOR

[LH&RH FRONT WINDOW ANTI-PINCH]

< DTC/CIRCUIT DIAGNOSIS >

>> End.

REAR LH

REAR LH : Description

INFOID:000000007253496

Door glass moves UP/DOWN by receiving the signal from main power window and door lock/unlock switch or rear power window switch LH.

REAR LH : Component Function Check

INFOID:000000007253497

1. CHECK REAR POWER WINDOW MOTOR LH CIRCUIT

Check that rear power window motor LH operates with main power window and door lock/unlock switch or rear power window switch LH.

Is the inspection result normal?

- YES >> Rear power window motor LH is OK.
- NO >> Refer to [PWC-29, "REAR LH : Diagnosis Procedure"](#)

REAR LH : Diagnosis Procedure

INFOID:000000007253498

Regarding Wiring Diagram information, refer to [PWC-81, "Wiring Diagram"](#).

1. CHECK REAR POWER WINDOW MOTOR LH

Check rear power window motor LH. Refer to [PWC-30, "REAR LH : Component Inspection"](#).

Is the inspection result normal?

- YES >> GO TO 2
- NO >> Replace rear power window motor LH. Refer to [GW-22, "Rear Door Glass Regulator"](#).

2. CHECK REAR POWER WINDOW SWITCH OUTPUT SIGNAL

1. Disconnect rear power window motor LH connector.
2. Turn ignition switch ON.
3. Check voltage between rear power window motor LH connector D204 terminal 1, 3 and ground.

Terminal (+)		Terminal (-)	Window condition	Voltage (V) (Approx.)
Rear power window motor LH connector	Terminal			
D204	3	Ground	UP	Battery voltage
			DOWN	0
	1		UP	0
			DOWN	Battery voltage

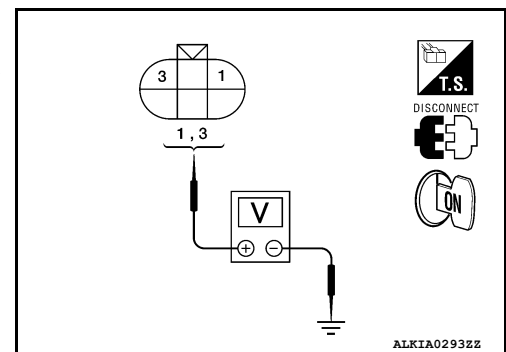

Is the inspection result normal?

- YES >> Check intermittent incident. Refer to [GI-39, "Intermittent Incident"](#).
- NO >> GO TO 3

3. CHECK HARNESS CONTINUITY

A
B
C
D
E
F
G
H
I
J
L
M
N
O
P

PWC

POWER WINDOW MOTOR

[LH&RH FRONT WINDOW ANTI-PINCH]

< DTC/CIRCUIT DIAGNOSIS >

1. Turn ignition switch OFF.
2. Disconnect rear power window switch LH connector.
3. Check continuity between rear power window switch LH connector D203 (A) terminals 4, 5 and rear power window motor LH connector D204 (B) terminals 1, 3.

Rear power window switch LH connector	Terminal	Rear power window motor LH connector	Terminal	Continuity
D203 (A)	5	D204 (B)	1	Yes
	4		3	

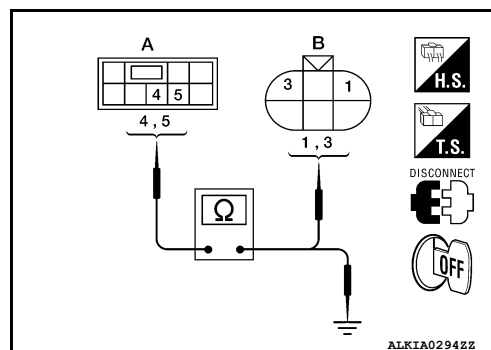

4. Check continuity between rear power window switch LH connector D203 (A) terminals 4, 5 and ground.

Rear power window switch LH connector	Terminal	Ground	Continuity
D203 (A)	5	Ground	No
	4		

Is the inspection result normal?

- YES >> Check rear power window switch LH. Refer to [PWC-22. "Diagnosis Procedure"](#).
 NO >> Repair or replace harness or connectors.

REAR LH : Component Inspection

INFOID:000000007253499

COMPONENT INSPECTION

1. CHECK REAR POWER WINDOW MOTOR LH

1. Disconnect rear power window motor LH.
2. Check motor operation by connecting battery voltage directly to rear power window motor LH.

Terminal		Motor condition
(+)	(-)	
3	1	UP
1	3	DOWN

Is the inspection result normal?

- YES >> Inspection End.
 NO >> Replace rear power window motor LH. Refer to [GW-22. "Rear Door Glass Regulator"](#).

REAR RH

REAR RH : Description

INFOID:000000007253500

Door glass moves UP/DOWN by receiving the signal from main power window and door lock/unlock switch or rear power window switch RH.

REAR RH : Component Function Check

INFOID:000000007253501

1. CHECK REAR POWER WINDOW MOTOR RH CIRCUIT

Check that rear power window motor RH operates with main power window and door lock/unlock switch or rear power window switch RH.

Is the inspection result normal?

- YES >> Rear power window motor RH is OK.
 NO >> Refer to [PWC-30. "REAR RH : Diagnosis Procedure"](#).

REAR RH : Diagnosis Procedure

INFOID:000000007253502

POWER WINDOW MOTOR

[LH&RH FRONT WINDOW ANTI-PINCH]

< DTC/CIRCUIT DIAGNOSIS >

Regarding Wiring Diagram information, refer to [PWC-81. "Wiring Diagram"](#).

1. CHECK REAR POWER WINDOW MOTOR RH

Check rear power window motor RH. Refer to [PWC-31. "REAR RH : Component Inspection"](#).

Is the inspection result normal?

YES >> GO TO 2

NO >> Replace rear power window motor RH. Refer to [GW-13. "Removal and Installation"](#).

2. CHECK REAR POWER WINDOW SWITCH RH OUTPUT SIGNAL

1. Disconnect rear power window motor RH connector.
2. Turn ignition switch ON.
3. Check voltage between rear power window motor RH connector D304 terminal 1, 3 and ground.

Terminal (+)		Terminal (-)	Rear power window switch RH condition	Voltage (V) (Approx.)
Rear power window motor RH connector	Terminal			
D304	3	Ground	UP	Battery voltage
			DOWN	0
	1		UP	0
			DOWN	Battery voltage

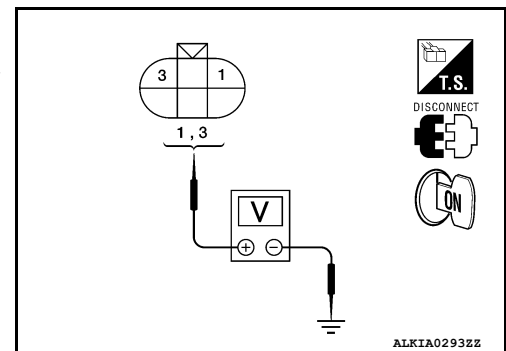

Is the inspection result normal?

YES >> Check intermittent incident. Refer to [GI-39. "Intermittent Incident"](#).

NO >> GO TO 3

3. CHECK HARNESS CONTINUITY

1. Turn ignition switch OFF.
2. Disconnect rear power window switch RH connector.
3. Check continuity between rear power window switch RH connector D303 (A) terminals 4, 5 and rear power window motor RH connector D304 (B) terminals 1, 3.

Rear power window switch RH connector	Terminal	Rear power window motor RH connector	Terminal	Continuity
D303 (A)	5	D304 (B)	1	Yes
	4		3	

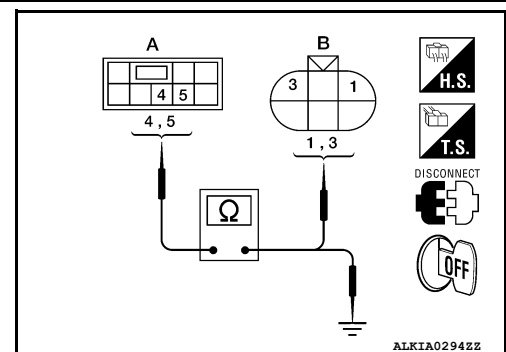

4. Check continuity between rear power window switch RH connector D303 (A) terminals 4, 5 and ground.

Rear power window switch RH connector	Terminal	Ground	Continuity
D303 (A)	5		
	4		

Is the inspection result normal?

YES >> Check rear power window switch RH. Refer to [PWC-22. "Diagnosis Procedure"](#).

NO >> Repair or replace harness or connectors.

REAR RH : Component Inspection

INFOID:000000007253503

COMPONENT INSPECTION

1. CHECK REAR POWER WINDOW MOTOR RH

POWER WINDOW MOTOR

< DTC/CIRCUIT DIAGNOSIS >

[LH&RH FRONT WINDOW ANTI-PINCH]

1. Disconnect rear power window motor RH.
2. Check motor operation by connecting battery voltage directly to rear power window motor RH.

Terminal		Motor condition
(+)	(-)	
3	1	UP
1	3	DOWN

Is the inspection result normal?

YES >> Inspection End.

NO >> Replace rear power window motor RH. Refer to [GW-22. "Rear Door Glass Regulator"](#).

ENCODER

< DTC/CIRCUIT DIAGNOSIS >

[LH&RH FRONT WINDOW ANTI-PINCH]

ENCODER DRIVER SIDE

DRIVER SIDE : Description

INFOID:000000007253504

Detects condition of the front power window motor LH operation and transmits to main power window and door lock/unlock switch as pulse signal.

DRIVER SIDE : Component Function Check

INFOID:000000007253505

1. CHECK ENCODER OPERATION

Check that front door glass LH performs AUTO open/close operation normally when operating main power window and door lock/unlock switch.

Is the inspection result normal?

YES >> Encoder operation is OK.

NO >> Refer to [PWC-33, "DRIVER SIDE : Diagnosis Procedure"](#).

DRIVER SIDE : Diagnosis Procedure

INFOID:000000007253506

Regarding Wiring Diagram information, refer to [PWC-81, "Wiring Diagram"](#).

1. CHECK ENCODER OPERATION

1. Turn ignition switch ON.
2. Check signal between main power window and door lock/unlock switch connector D7 terminals 9, 13 and ground with oscilloscope.

Terminals		Signal (Reference value)
(+)	(-)	
Main power window and door lock/unlock switch connector	Terminal	Ground
D7	9 13	
		Refer to following signal

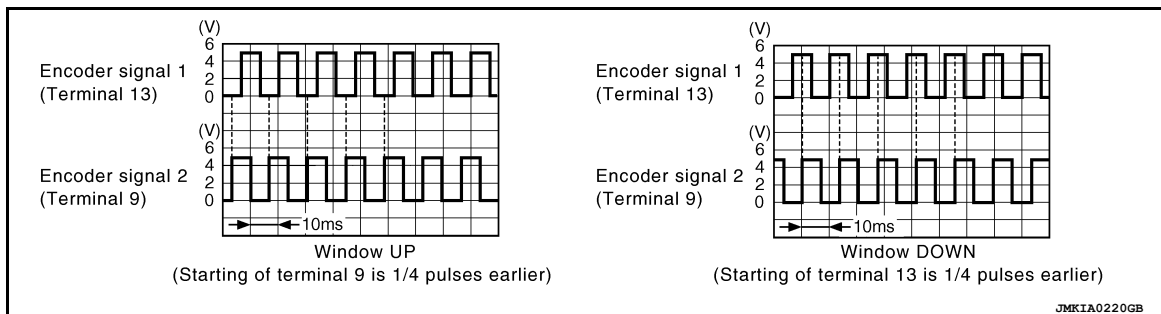
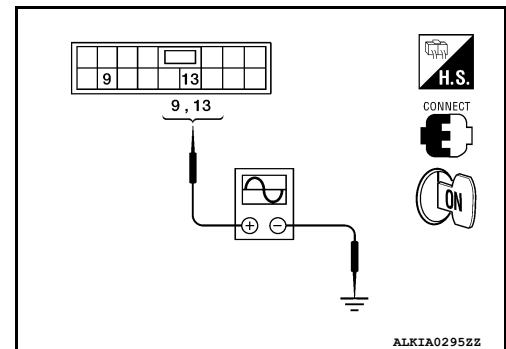

Is the inspection result normal?

YES >> Check intermittent incident. Refer to [GI-39, "Intermittent Incident"](#).

NO >> GO TO 2

2. CHECK ENCODER POWER SUPPLY

ENCODER

[LH&RH FRONT WINDOW ANTI-PINCH]

< DTC/CIRCUIT DIAGNOSIS >

Check voltage between front power window motor LH connector D9 terminal 4 and ground.

Terminal		Voltage (V) (Approx.)	
(+)	(-)		
Front power window motor LH connector	Terminal		
D9	4	Ground	
			10

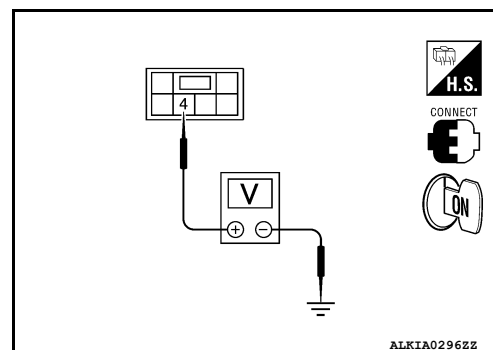

Is the inspection result normal?

YES >> GO TO 4

NO >> GO TO 3

3. CHECK HARNESS CONTINUITY 1

- Turn ignition switch OFF.
- Disconnect main power window and door lock/unlock switch connector D7 and front power window motor LH connector.
- Check continuity between main power window and door lock/unlock switch connector D7 (A) terminal 15 and front power window motor LH connector D9 (B) terminal 4.

Main power window and door lock/unlock switch connector	Terminal	Front power window motor LH connector	Terminal	Continuity
D7 (A)	15	D9 (B)	4	Yes

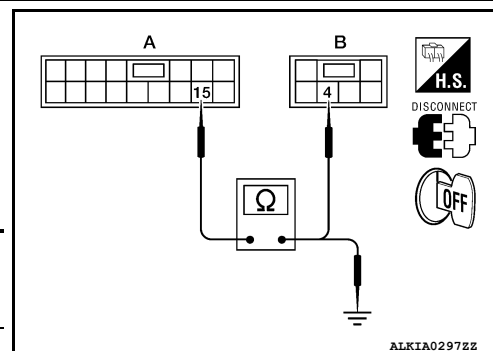

- Check continuity between main power window and door lock/unlock switch connector D7 (A) terminal 15 and ground.

Main power window and door lock/unlock switch connector	Terminal	Ground	Continuity
D7 (A)	15		No

Is the inspection result normal?

YES >> Replace main power window and door lock/unlock switch. Refer to [PWC-105, "Removal and Installation"](#).

NO >> Repair or replace harness or connectors.

4. CHECK ENCODER GROUND CIRCUIT

- Turn ignition switch OFF.
- Disconnect front power window motor LH connector.
- Check continuity between front power window motor LH connector D9 terminal 6 and ground.

Front power window motor LH connector	Terminal	Ground	Continuity
D9	6		Yes

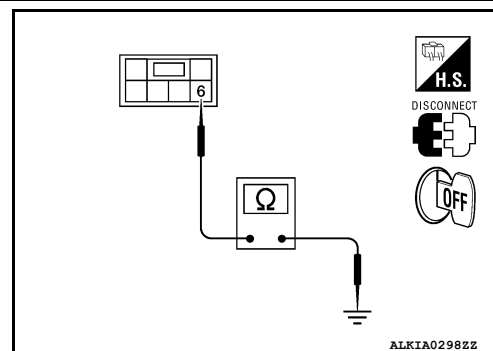

Is the inspection result normal?

YES >> GO TO 6

NO >> GO TO 5

5. CHECK HARNESS CONTINUITY 2

ENCODER

[LH&RH FRONT WINDOW ANTI-PINCH]

< DTC/CIRCUIT DIAGNOSIS >

1. Disconnect main power window and door lock/unlock switch connector D7.
2. Check continuity between main power window and door lock/unlock switch connector D7 (A) terminal 2 and front power window motor LH connector D9 (B) terminal 6.

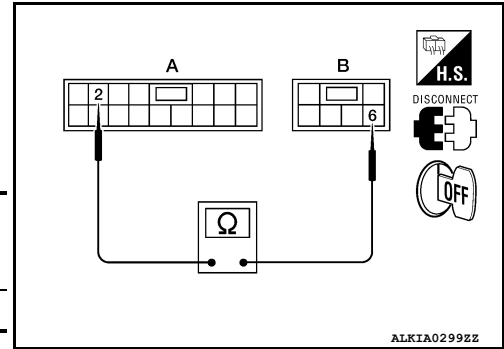

Main power window and door lock/unlock switch connector	Terminal	Front power window motor LH connector	Terminal	Continuity
D7 (A)	2	D9 (B)	6	Yes

Is the inspection result normal?

YES >> Replace main power window and door lock/unlock switch. Refer to [PWC-105, "Removal and Installation"](#).

NO >> Repair or replace harness or connectors.

6. CHECK HARNESS CONTINUITY 3

1. Disconnect main power window and door lock/unlock switch connector D7.
2. Check continuity between main power window and door lock/unlock switch connector D7 (A) terminals 9, 13 and front power window motor LH connector D9 (B) terminals 3, 5.

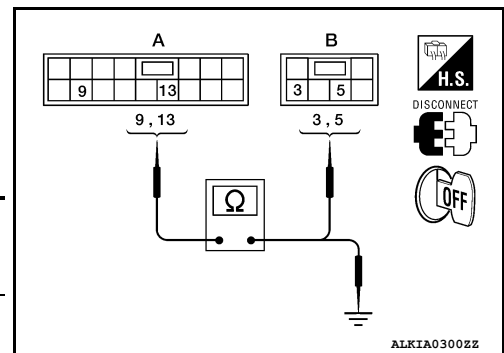

Main power window and door lock/unlock switch connector	Terminal	Front power window motor LH connector	Terminal	Continuity
D7 (A)	9	D9 (B)	5	Yes
	13		3	

3. Check continuity between main power window and door lock/unlock switch connector D7 (A) terminals 9, 13 and ground.

Main power window and door lock/unlock switch connector	Terminal	Ground	Continuity
D7 (A)	9	Ground	No
	13		

Is the inspection result normal?

YES >> Replace front power window motor LH. Refer to [GW-17, "Removal and Installation"](#).

NO >> Repair or replace harness or connectors.

DRIVER SIDE : Special Repair Requirement

INFOID:000000007253507

1. PERFORM INITIALIZATION PROCEDURE

Perform initialization procedure. Refer to [PWC-7, "ADDITIONAL SERVICE WHEN REMOVING BATTERY NEGATIVE TERMINAL : Special Repair Requirement"](#) and [PWC-7, "ADDITIONAL SERVICE WHEN REPLACING CONTROL UNIT : Special Repair Requirement"](#).

>> GO TO 2

2. CHECK ANTI-PINCH OPERATION

Check anti-pinch operation. Refer to [PWC-7, "ADDITIONAL SERVICE WHEN REMOVING BATTERY NEGATIVE TERMINAL : Special Repair Requirement"](#) and [PWC-7, "ADDITIONAL SERVICE WHEN REPLACING CONTROL UNIT : Special Repair Requirement"](#).

>> End.

PASSENGER SIDE

A
B
C
D
E
F
G
H
I
J
L
M
N
O
P

PWC

ENCODER

< DTC/CIRCUIT DIAGNOSIS >

[LH&RH FRONT WINDOW ANTI-PINCH]

PASSENGER SIDE : Description

INFOID:000000007253508

Detects condition of the front power window motor RH operation and transmits to power window and door lock/unlock switch RH as pulse signal.

PASSENGER SIDE : Component Function Check

INFOID:000000007253509

1. CHECK ENCODER OPERATION

Check that front door glass RH performs AUTO open/close operation normally when operating power window and door lock/unlock switch RH.

Is the inspection result normal?

YES >> Encoder operation is OK.

NO >> Refer to [PWC-36, "PASSENGER SIDE : Diagnosis Procedure"](#).

PASSENGER SIDE : Diagnosis Procedure

INFOID:000000007253510

Regarding Wiring Diagram information, refer to [PWC-81, "Wiring Diagram"](#).

1. CHECK ENCODER SIGNAL

1. Turn ignition switch ON.
2. Check signal between power window and door lock/unlock switch RH connector D105 terminal 12, 15 and ground with oscilloscope.

Terminals		Signal (Reference value)
(+)	(-)	
Power window and door lock/unlock switch RH connector	Terminal	Refer to following signal
D105	12	
	15	Ground

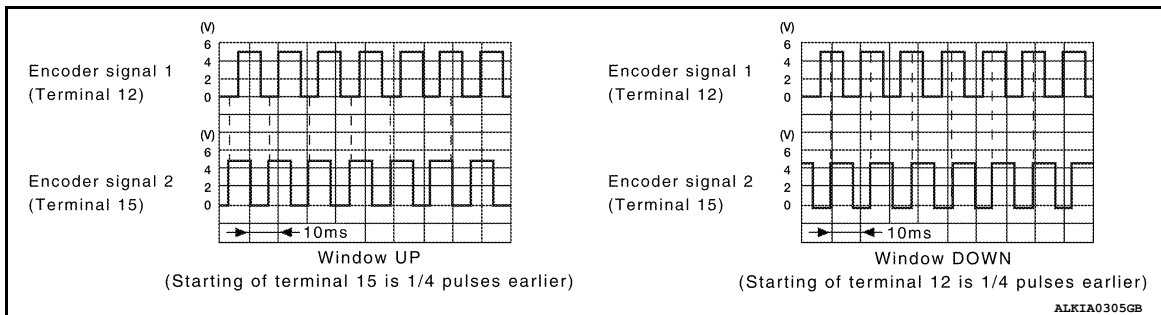
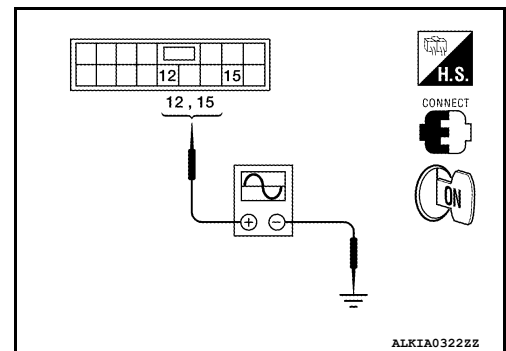

Is the inspection result normal?

YES >> Check intermittent incident. Refer to [GI-39, "Intermittent Incident"](#).

NO >> GO TO 2

2. CHECK ENCODER POWER SUPPLY

ENCODER

< DTC/CIRCUIT DIAGNOSIS >

[LH&RH FRONT WINDOW ANTI-PINCH]

Check voltage between front power window motor RH connector D104 terminal 4 and ground.

Terminal		Voltage (V) (Approx.)
(+)	(-)	
Front power window motor RH connector	Terminal	
D104	4	Ground
		10

Is the inspection result normal?

YES >> GO TO 4

NO >> GO TO 3

3. CHECK HARNESS CONTINUITY 1

1. Turn ignition switch OFF.
2. Disconnect power window and door lock/unlock switch RH and front power window motor RH connectors.
3. Check continuity between power window and door lock/unlock switch RH connector D105 (A) terminal 4 and front power window motor RH connector D104 (B) terminal 4.

Power window and door lock/unlock switch RH connector	Terminal	Front power window motor RH connector	Terminal	Continuity
D105 (A)	4	D104 (B)	4	Yes

4. Check continuity between power window and door lock/unlock switch RH connector D105 (A) terminal 4 and ground.

Power window and door lock/unlock switch RH connector	Terminal	Ground	Continuity
D105 (A)	4		No

Is the inspection result normal?

YES >> Replace power window and door lock/unlock switch RH. Refer to [PWC-106. "Removal and Installation"](#).

NO >> Repair or replace harness or connectors.

4. CHECK ENCODER GROUND CIRCUIT

1. Turn ignition switch OFF.
2. Disconnect front power window motor RH connector.
3. Check continuity between front power window motor RH connector D104 terminal 6 and ground.

Front power window motor RH connector	Terminal	Ground	Continuity
D104	6		Yes

Is the inspection result normal?

YES >> GO TO 6

NO >> GO TO 5

5. CHECK HARNESS CONTINUITY 2

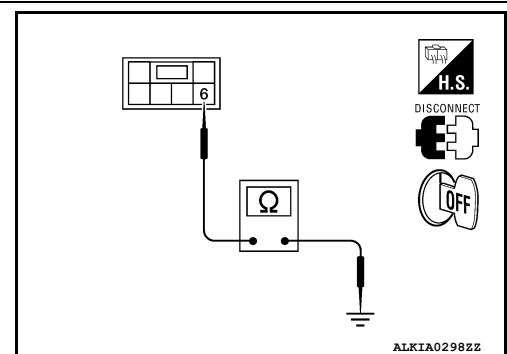
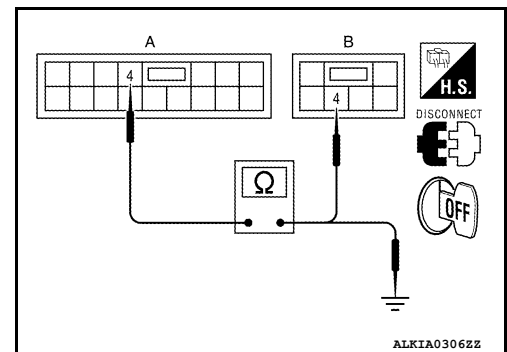
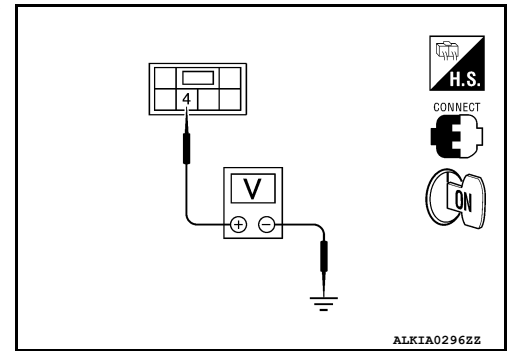

A
B
C
D
E
F
G
H
I
J
L
M
N
O
P

PWC

ENCODER

< DTC/CIRCUIT DIAGNOSIS >

[LH&RH FRONT WINDOW ANTI-PINCH]

1. Disconnect power window and door lock/unlock switch RH connector.
2. Check continuity between power window and door lock/unlock switch RH connector D105 (A) terminal 3 and front power window motor RH connector D104 (B) terminal 6.

Power window and door lock/unlock switch RH connector	Terminal	Front power window motor RH connector	Terminal	Continuity
D105 (A)	3	D104 (B)	6	Yes

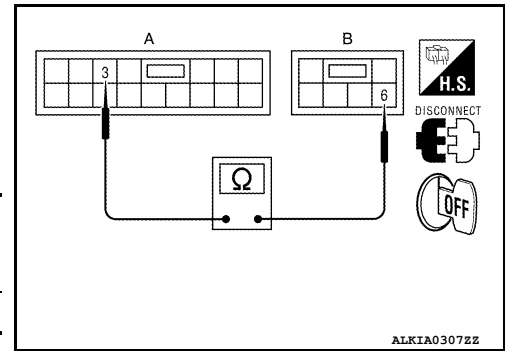

Is the inspection result normal?

- YES >> Replace power window and door lock/unlock switch RH. Refer to [PWC-106, "Removal and Installation"](#).
- NO >> Repair or replace harness or connectors.

6. CHECK HARNESS CONTINUITY 3

1. Disconnect power window and door lock/unlock switch RH connector.
2. Check continuity between power window and door lock/unlock switch RH connector D105 (A) terminals 12, 15 and front power window motor RH connector D104 (B) terminals 3, 5.

Power window and door lock/unlock switch RH connector	Terminal	Front power window motor RH connector	Terminal	Continuity
D105 (A)	12	D104 (B)	3	Yes
	15		5	

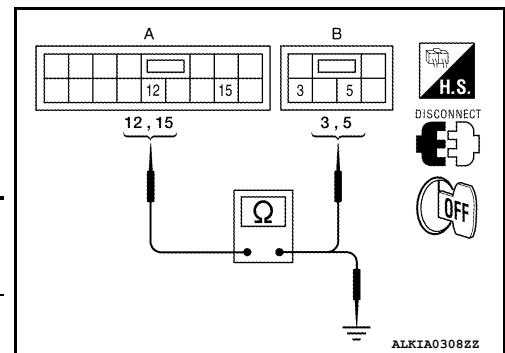

3. Check continuity between power window and door lock/unlock switch RH connector D105 (A) terminals 12, 15 and ground.

Power window and door lock/unlock switch RH connector	Terminal	Ground	Continuity
D105 (A)	12		No
	15		

Is the inspection result normal?

- YES >> Replace front power window motor RH. Refer to [GW-17, "Removal and Installation"](#).
- NO >> Repair or replace harness or connectors.

PASSENGER SIDE : Special Repair Requirement

INFOID:000000007253511

1. PERFORM INITIALIZATION PROCEDURE

Perform initialization procedure. Refer to [PWC-7, "ADDITIONAL SERVICE WHEN REMOVING BATTERY NEGATIVE TERMINAL : Special Repair Requirement"](#) and [PWC-7, "ADDITIONAL SERVICE WHEN REPLACING CONTROL UNIT : Special Repair Requirement"](#).

>> GO TO 2

2. CHECK ANTI-PINCH OPERATION

Check anti-pinch operation. Refer to [PWC-7, "ADDITIONAL SERVICE WHEN REMOVING BATTERY NEGATIVE TERMINAL : Special Repair Requirement"](#) and [PWC-7, "ADDITIONAL SERVICE WHEN REPLACING CONTROL UNIT : Special Repair Requirement"](#).

>> End.

DOOR SWITCH

< DTC/CIRCUIT DIAGNOSIS >

[LH&RH FRONT WINDOW ANTI-PINCH]

DOOR SWITCH

Description

INFOID:000000007253512

Detects door open/close condition.

Component Function Check

INFOID:000000007253513

1.CHECK FUNCTION

With CONSULT

Check door switches DOOR SW-DR and DOOR SW-AS in Data Monitor mode with CONSULT.

Monitor item	Condition
DOOR SW-DR	CLOSE → OPEN: OFF → ON
DOOR SW-AS	

Is the inspection result normal?

- YES >> Door switch is OK.
- NO >> Refer to [PWC-39, "Diagnosis Procedure"](#).

Diagnosis Procedure

INFOID:000000007253514

Regarding Wiring Diagram information, refer to [PWC-81, "Wiring Diagram"](#).

1.CHECK DOOR SWITCH INPUT SIGNAL

1. Turn ignition switch OFF.
2. Check signal between BCM connector and ground with oscilloscope.

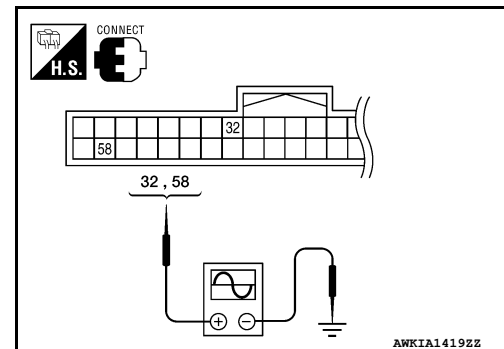

DOOR SWITCH

< DTC/CIRCUIT DIAGNOSIS >

[LH&RH FRONT WINDOW ANTI-PINCH]

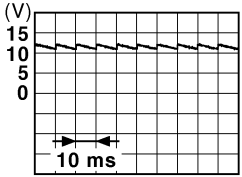
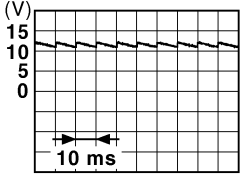
Terminals		(-)	Door condition	Voltage (V) (Approx.)	
(+) BCM connector					
Terminal	BCM connector				
58	A: M18	Ground	Driver side	OPEN	0
			Driver side	CLOSE	
Passenger side	OPEN		0		
Passenger side	CLOSE				

Is the inspection result normal?

- YES >> GO TO 4
- NO >> GO TO 2

2. CHECK DOOR SWITCH CIRCUIT

1. Disconnect BCM connector.
2. Check continuity between BCM connector and door switch connector.

BCM connector	Terminal	Door switch connector	Terminal	Continuity
M18	58	B8 (Driver side)	2	Yes
	32	B108 (Passenger side)		

3. Check continuity between BCM connector and ground.

BCM connector	Terminal	Ground	Continuity
M18	58	Ground	No
	32		

Is the inspection result normal?

- YES >> GO TO 3
- NO >> Repair or replace harness between BCM and door switch.

3. CHECK DOOR SWITCH

Refer to [PWC-41. "Component Inspection"](#).

Is the inspection result normal?

- YES >> GO TO 4
- NO >> Replace malfunctioning door switch.

4. CHECK INTERMITTENT INCIDENT

Refer to [GI-39. "Intermittent Incident"](#).

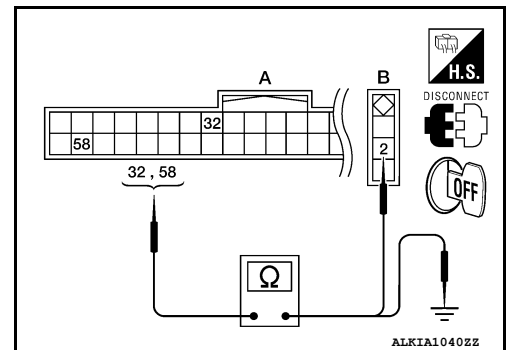

DOOR SWITCH

< DTC/CIRCUIT DIAGNOSIS >

[LH&RH FRONT WINDOW ANTI-PINCH]

>> Inspection End.

Component Inspection

INFOID:000000007253515

1. CHECK DOOR SWITCH

1. Turn ignition switch OFF.
2. Disconnect door switch connector.
3. Check door switch.

Terminal		Door switch condition	Continuity
Door switch			
2	Ground part of door switch	Pressed	No
		Released	Yes

Is the inspection result normal?

- YES >> Inspection End.
NO >> Replace malfunctioning door switch.

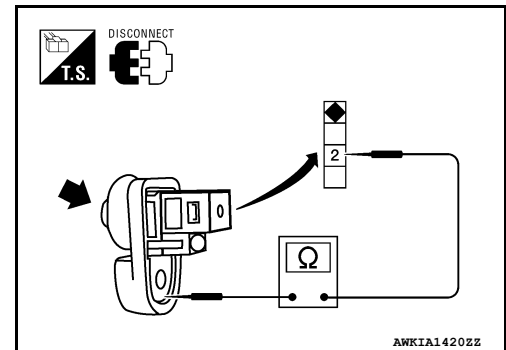

A
B
C
D
E
F
G
H
I
J
L
M
N
O
P

PWC

DOOR KEY CYLINDER SWITCH

[LH&RH FRONT WINDOW ANTI-PINCH]

< DTC/CIRCUIT DIAGNOSIS >

DOOR KEY CYLINDER SWITCH

Description

INFOID:000000007253516

The main power window and door lock/unlock switch detects condition of the door key cylinder switch and transmits to BCM as the LOCK or UNLOCK signal.

Component Function Check

INFOID:000000007253517

1. CHECK DOOR KEY CYLINDER SWITCH INPUT SIGNAL

Check KEY CYL UN-SW, KEY CYL UN-SW in "DATA MONITOR" mode for "POWER DOOR LOCK SYSTEM" with CONSULT. Refer to [BCS-19. "DOOR LOCK : CONSULT Function \(BCM - DOOR LOCK\)".](#)

Monitor item	Condition
KEY CYL LK-SW	Lock : ON
	Neutral / Unlock : OFF
KEY CYL UN-SW	Unlock : ON
	Neutral / Lock : OFF

Is the inspection result normal?

- YES >> Key cylinder switch is OK.
- NO >> Refer to [PWC-42. "Diagnosis Procedure".](#)

Diagnosis Procedure

INFOID:000000007253518

Regarding Wiring Diagram information, refer to [PWC-81. "Wiring Diagram".](#)

1. CHECK DOOR KEY CYLINDER SWITCH INPUT SIGNAL

1. Turn ignition switch ON.
2. Check voltage between main power window and door lock/unlock switch connector and ground.

Terminals		Key position	Voltage (V) (Approx.)
(+)	(-)		
Main power window and door lock/unlock switch connector	Terminal		
	D7	Ground	
	4	Lock	0
		Neutral / Unlock	5
	6	Unlock	0
		Neutral / Lock	5

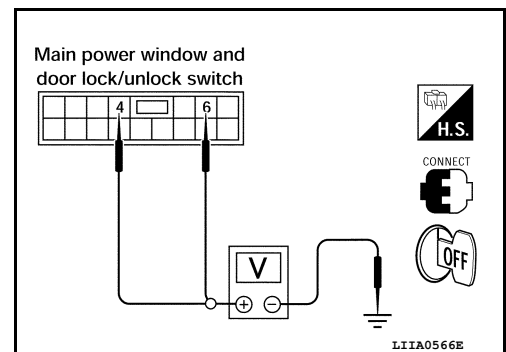

Is the inspection result normal?

- YES >> Replace main power window and door lock/unlock switch. Refer to [PWC-105. "Removal and Installation".](#) After that, refer to [PWC-7. "ADDITIONAL SERVICE WHEN REPLACING CONTROL UNIT : Special Repair Requirement".](#)
- NO >> GO TO 2

2. CHECK DOOR KEY CYLINDER SIGNAL CIRCUIT

1. Turn ignition switch OFF.

DOOR KEY CYLINDER SWITCH

[LH&RH FRONT WINDOW ANTI-PINCH]

< DTC/CIRCUIT DIAGNOSIS >

- Disconnect main power window and door lock/unlock switch connector and front door lock assembly LH (key cylinder switch) connector.
- Check continuity between main power window and door lock/unlock switch connector and front door lock assembly LH (key cylinder switch) connector.

Main power window and door lock/unlock switch connector	Terminal	Front door lock assembly LH (key cylinder switch) connector	Terminal	Continuity
A: D7	4	B: D10	6	Yes
	6		5	

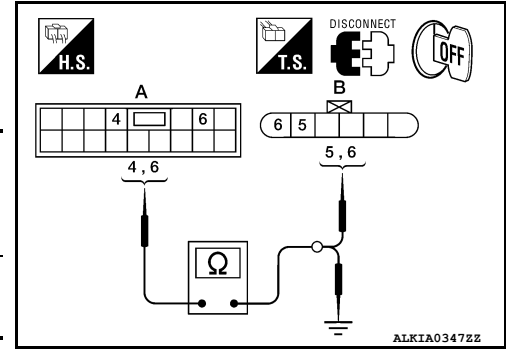

- Check continuity between main power window and door lock/unlock switch connector and ground.

Power window main switch connector	Terminal	Ground	Continuity
A: D7	4	Ground	No
	6		

Is the inspection result normal?

- YES >> GO TO 3
 NO >> Repair or replace harness.

3. CHECK DOOR KEY CYLINDER SWITCH GROUND CIRCUIT

Check continuity between front door lock assembly LH connector and ground.

Front door lock assembly LH connector	Terminal	Ground	Continuity
D10	4	Ground	Yes

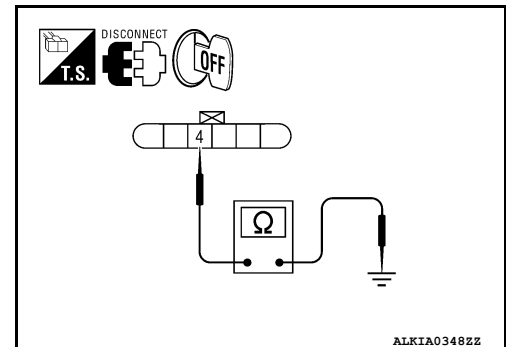

Is the inspection result normal?

- YES >> GO TO 4
 NO >> Repair or replace harness.

4. CHECK DOOR KEY CYLINDER SWITCH

Check door key cylinder switch.

Refer to [PWC-43, "Component Inspection"](#).

Is the inspection result normal?

- YES >> Check intermittent incident. Refer to [GI-39, "Intermittent Incident"](#).
 NO >> Replace front door lock assembly LH (key cylinder switch). Refer to [DLK-222, "FRONT DOOR LOCK : Removal and Installation"](#). After that, Refer to [PWC-7, "ADDITIONAL SERVICE WHEN REPLACING CONTROL UNIT : Special Repair Requirement"](#).

Component Inspection

INFOID:000000007253519

COMPONENT INSPECTION

1. CHECK DOOR KEY CYLINDER SWITCH

DOOR KEY CYLINDER SWITCH

< DTC/CIRCUIT DIAGNOSIS >

[LH&RH FRONT WINDOW ANTI-PINCH]

Check front door lock assembly LH (key cylinder switch).

Terminal		Key position	Continuity
Front door lock assembly LH (key cylinder switch) connector			
5	4	Unlock	Yes
		Neutral / Lock	No
6		Lock	Yes
		Neutral / Unlock	No

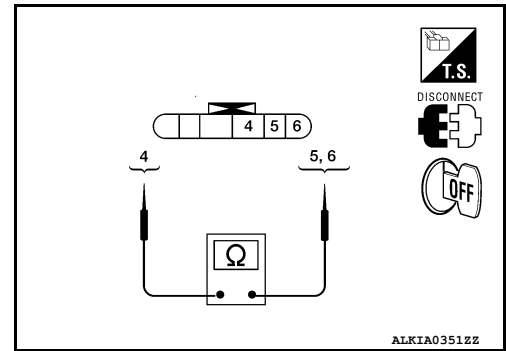

Is the inspection result normal?

YES >> Key cylinder switch is OK.

NO >> Replace front door lock assembly LH (key cylinder switch). Refer to [DLK-222, "FRONT DOOR LOCK : Removal and Installation"](#). After that, refer to [PWC-44, "Special Repair Requirement"](#).

Special Repair Requirement

INFOID:000000007253520

1.PERFORM INITIALIZATION PROCEDURE

Perform initialization procedure.

Refer to [DLK-8, "ADDITIONAL SERVICE WHEN REPLACING CONTROL UNIT : Special Repair Requirement"](#).

Is the inspection result normal?

YES >> Inspection End.

NO >> Check intermittent incident. Refer to [GI-39, "Intermittent Incident"](#).

POWER WINDOW SERIAL LINK

[LH&RH FRONT WINDOW ANTI-PINCH]

< DTC/CIRCUIT DIAGNOSIS >

POWER WINDOW SERIAL LINK

POWER WINDOW MAIN SWITCH

POWER WINDOW MAIN SWITCH : Description

INFOID:000000007253521

- Main power window and door lock/unlock switch, power window and door lock/unlock switch RH and BCM communicate via the power window serial link.
- The keyless power window down signal is transmitted from BCM to main power window and door lock/unlock switch and power window and door lock/unlock switch RH.
- The following signals are transmitted from main power window and door lock/unlock switch to power window and door lock/unlock switch RH:
 - Front door window RH operation
 - Power window control by key cylinder switch
 - Power window lock switch
 - Retained accessory power operation

POWER WINDOW MAIN SWITCH : Component Function Check

INFOID:000000007253522

1. CHECK POWER WINDOW SWITCH OUTPUT SIGNAL

Check ("CDL LOCK SW", "CDL UNLOCK SW") in "DATA MONITOR" mode for "POWER DOOR LOCK SYSTEM" with CONSULT. Refer to [BCS-19, "DOOR LOCK : CONSULT Function \(BCM - DOOR LOCK\)"](#).

Monitor item	Condition
CDL LOCK SW	LOCK : ON
	UNLOCK : OFF
CDL UNLOCK SW	LOCK : OFF
	UNLOCK : ON

Is the inspection result normal?

YES >> Power window serial link is OK.

NO >> Refer to [PWC-45, "POWER WINDOW MAIN SWITCH : Diagnosis Procedure"](#).

POWER WINDOW MAIN SWITCH : Diagnosis Procedure

INFOID:000000007253523

PWC

Regarding Wiring Diagram information, refer to [PWC-81, "Wiring Diagram"](#).

1. CHECK POWER WINDOW SWITCH OUTPUT SIGNAL

1. Remove Intelligent Key, and close front door LH and RH.
2. Check signal between BCM connector M18 terminal 40 and ground with oscilloscope when door lock and unlock switch (key cylinder switch) is turned to "LOCK" or "UNLOCK".
3. Check that signals which are shown in the figure below can be detected during 10 seconds just after door lock and unlock switch (key cylinder switch) is turned to "LOCK" or "UNLOCK".

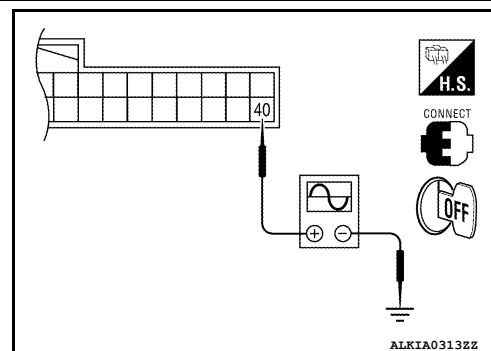

POWER WINDOW SERIAL LINK

< DTC/CIRCUIT DIAGNOSIS >

[LH&RH FRONT WINDOW ANTI-PINCH]

Terminal (+)		Terminal (-)	Signal (Reference value)
BCM connector	Terminal		
M18	40	Ground	<p>PIIA1297E</p>

Is the inspection result normal?

- YES >> Power window serial link is OK.
- NO >> GO TO 2

2. CHECK POWER WINDOW SERIAL LINK CIRCUIT

1. Turn ignition switch OFF.
2. Disconnect BCM connector M18 and main power window and door lock/unlock switch connector D7.
3. Check continuity between BCM connector M18 (A) terminal 40 and main power window and door lock/unlock switch connector D7 (B) terminal 14.

BCM connector	Terminal	Main power window and door lock/unlock switch connector	Terminal	Continuity
M18 (A)	40	D7 (B)	14	Yes

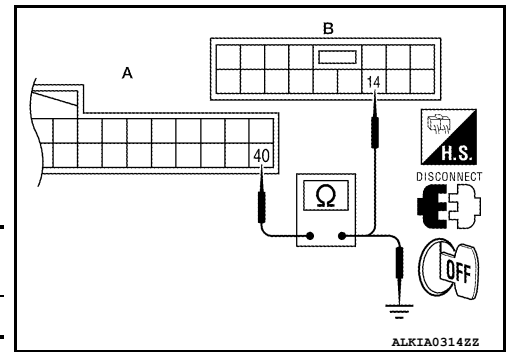

4. Check continuity between BCM connector M18 (A) terminal 40 and ground.

BCM connector	Terminal	Ground	Continuity
M18 (A)	40		No

Is the inspection result normal?

- YES >> Replace main power window and door lock/unlock switch. Refer to [PWC-105, "Removal and Installation"](#).
- NO >> Repair or replace harness or connectors.

POWER WINDOW MAIN SWITCH : Special Repair Requirement

INFOID:000000007253524

1. PERFORM INITIALIZATION PROCEDURE

Perform initialization procedure. Refer to [PWC-7, "ADDITIONAL SERVICE WHEN REMOVING BATTERY NEGATIVE TERMINAL : Special Repair Requirement"](#) and [PWC-7, "ADDITIONAL SERVICE WHEN REPLACING CONTROL UNIT : Special Repair Requirement"](#).

>> GO TO 2

2. CHECK ANTI-PINCH OPERATION

Check anti-pinch operation. Refer to [PWC-7, "ADDITIONAL SERVICE WHEN REMOVING BATTERY NEGATIVE TERMINAL : Special Repair Requirement"](#) and [PWC-7, "ADDITIONAL SERVICE WHEN REPLACING CONTROL UNIT : Special Repair Requirement"](#).

>> End.

FRONT POWER WINDOW SWITCH

POWER WINDOW SERIAL LINK

[LH&RH FRONT WINDOW ANTI-PINCH]

< DTC/CIRCUIT DIAGNOSIS >

FRONT POWER WINDOW SWITCH : Description

INFOID:000000007253525

- Main power window and door lock/unlock switch, power window and door lock/unlock switch RH and BCM communicate via the power window serial link.
- The keyless power window down signal is transmitted from BCM to main power window and door lock/unlock switch and power window and door lock/unlock switch RH.
- The following signals are transmitted from main power window and door lock/unlock switch to power window and door lock/unlock switch RH:
 - Front door window RH operation
 - Power window control by key cylinder switch
 - Power window lock switch
 - Retained accessory power operation

FRONT POWER WINDOW SWITCH : Diagnosis Procedure

INFOID:000000007253526

Regarding Wiring Diagram information, refer to [PWC-81, "Wiring Diagram"](#).

1. CHECK POWER WINDOW AND DOOR LOCK/UNLOCK SWITCH RH

1. Remove Intelligent Key, and close the front door LH and RH.
2. Check signal between BCM connector M18 terminal 40 and ground with oscilloscope when door lock and unlock switch (key cylinder switch) is turned to "LOCK" or "UNLOCK".
3. Check that signals which are shown in the figure below can be detected during 10 seconds just after door lock and unlock switch (key cylinder switch) is turned to "LOCK" or "UNLOCK".

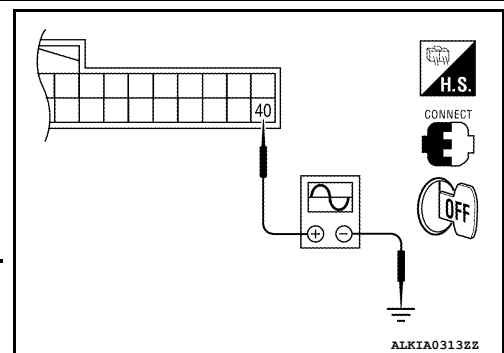

Terminal (+)		Terminal (-)	Signal (Reference value)
BCM connector	Terminal		
M18	40	Ground	

Is the inspection result normal?

- YES >> Power window serial link is OK.
 NO >> GO TO 2

2. CHECK POWER WINDOW SERIAL LINK CIRCUIT

1. Turn ignition switch OFF.
2. Disconnect BCM connector M18 and power window and door lock/unlock switch RH connector.
3. Check continuity between BCM connector M18 (A) terminal 40 and power window and door lock/unlock switch RH connector D105 (B) terminal 16.

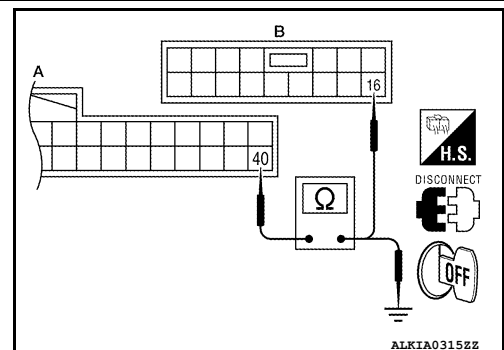

BCM connector	Terminal	Power window and door lock/unlock switch RH connector	Terminal	Continuity
M18 (A)	40	D105 (B)	16	Yes

4. Check continuity between BCM connector M18 (A) terminal 40 and ground.

A
B
C
D
E
F
G
H
I
J
L
M
N
O
P

PWC

POWER WINDOW SERIAL LINK

[LH&RH FRONT WINDOW ANTI-PINCH]

< DTC/CIRCUIT DIAGNOSIS >

BCM connector	Terminal	Ground	Continuity
M18 (A)	40		No

Is the inspection result normal?

YES >> Replace main power window and door lock/unlock switch. Refer to [PWC-105, "Removal and Installation"](#).

NO >> Repair or replace harness or connectors.

FRONT POWER WINDOW SWITCH : Special Repair Requirement

INFOID:000000007253527

1. PERFORM INITIALIZATION PROCEDURE

Perform initialization procedure. Refer to [PWC-7, "ADDITIONAL SERVICE WHEN REMOVING BATTERY NEGATIVE TERMINAL : Special Repair Requirement"](#) and [PWC-7, "ADDITIONAL SERVICE WHEN REPLACING CONTROL UNIT : Special Repair Requirement"](#).

>> GO TO 2

2. CHECK ANTI-PINCH OPERATION

Check anti-pinch operation. Refer to [PWC-7, "ADDITIONAL SERVICE WHEN REMOVING BATTERY NEGATIVE TERMINAL : Special Repair Requirement"](#) and [PWC-7, "ADDITIONAL SERVICE WHEN REPLACING CONTROL UNIT : Special Repair Requirement"](#).

>> End.

POWER WINDOW LOCK SWITCH

< DTC/CIRCUIT DIAGNOSIS >

[LH&RH FRONT WINDOW ANTI-PINCH]

POWER WINDOW LOCK SWITCH

Component Function Check

INFOID:000000007253528

1. CHECK POWER WINDOW LOCK

Activate the power window lock switch and verify that the front power window RH, rear power window LH and rear power window RH are inoperative.

Is the inspection result normal?

- YES >> Power window lock switch is OK.
- NO >> Refer to [PWC-49, "Component Inspection"](#).

Component Inspection

INFOID:000000007253529

1. CHECK POWER WINDOW LOCK SWITCH

1. Disconnect main power window and door lock/unlock switch connectors.
2. Check continuity between main power window and door lock/unlock switch (lock operation).

Terminal	Main power window and door lock/unlock switch condition	Continuity
3	Rear LH	UP
5	Rear RH	
1	Rear LH	NEUTRAL
3	Rear RH	
5	Rear RH	
7	Rear LH	DOWN
1	Rear RH	
7	Rear RH	

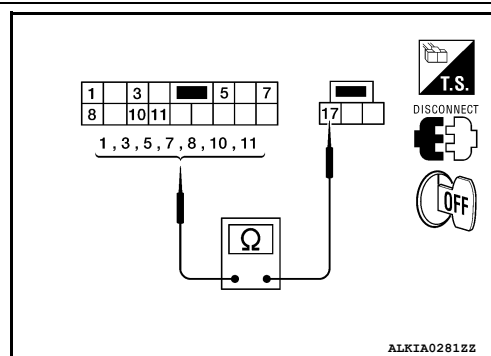

3. Check continuity between main power window and door lock/unlock switch (unlock operation).

Terminal	Main power window and door lock/unlock switch condition	Continuity
3	Rear LH	UP
5	Rear RH	
1	Rear LH	NEUTRAL
3	Rear RH	
5	Rear RH	
7	Rear LH	DOWN
1	Rear RH	
7	Rear RH	

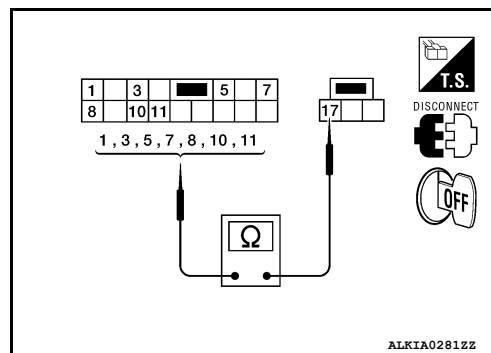

Is the inspection result normal?

- YES >> Inspection End.
- NO >> Replace main power window and door lock/unlock switch. Refer to [PWC-105, "Removal and Installation"](#).

Special Repair Requirement

INFOID:000000007253530

1. PERFORM INITIALIZATION PROCEDURE

A
B
C
D
E
F
G
H
I
J
L
M
N
O
P

PWC

POWER WINDOW LOCK SWITCH

< DTC/CIRCUIT DIAGNOSIS >

[LH&RH FRONT WINDOW ANTI-PINCH]

Perform initialization procedure. Refer to [PWC-7, "ADDITIONAL SERVICE WHEN REMOVING BATTERY NEGATIVE TERMINAL : Special Repair Requirement"](#) and [PWC-7, "ADDITIONAL SERVICE WHEN REPLACING CONTROL UNIT : Special Repair Requirement"](#).

>> GO TO 2

2. CHECK ANTI-PINCH OPERATION

Check anti-pinch operation. Refer to [PWC-7, "ADDITIONAL SERVICE WHEN REMOVING BATTERY NEGATIVE TERMINAL : Special Repair Requirement"](#) and [PWC-7, "ADDITIONAL SERVICE WHEN REPLACING CONTROL UNIT : Special Repair Requirement"](#).

>> End.

POWER WINDOW MAIN SWITCH

< ECU DIAGNOSIS INFORMATION >

[LH&RH FRONT WINDOW ANTI-PINCH]

ECU DIAGNOSIS INFORMATION

POWER WINDOW MAIN SWITCH

Reference Value

INFOID:000000007253531

TERMINAL LAYOUT

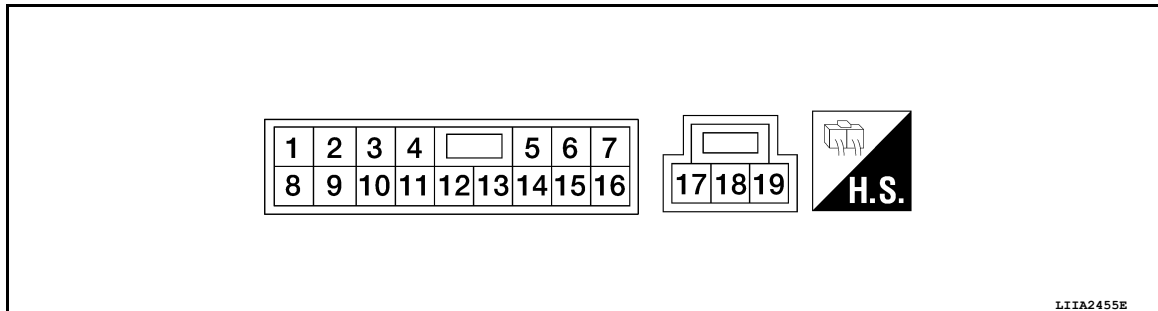

PHYSICAL VALUES

MAIN POWER WINDOW AND DOOR LOCK/UNLOCK SWITCH

Terminal No.		Description		Condition	Voltage [V] (Approx.)
+	-	Signal name	Input/ Output		
1 (W)	Ground	Rear power window motor LH UP signal	Output	When rear LH switch in power window main switch is operated UP.	Battery voltage
2 (GR)	Ground	Encoder ground	—	—	0
3 (Y)	Ground	Rear power window motor LH DOWN signal	Output	When rear LH switch in power window main switch is operated DOWN.	Battery voltage
4 (L)	Ground	Door key cylinder switch LH LOCK signal	Input	Key position (Neutral → Locked)	5 → 0
5 (SB)	Ground	Rear power window motor RH DOWN signal	Output	When rear RH switch in power window main switch is operated DOWN.	Battery voltage
6 (R)	Ground	Door key cylinder switch LH UNLOCK signal	Input	Key position (Neutral → Unlocked)	5 → 0
7 (P)	Ground	Rear power window motor RH UP signal	Output	When rear RH switch in power window main switch is operated UP.	Battery voltage
8 (L)	11	Front door power window motor LH UP signal	Output	When front LH switch in power window main switch is operated UP.	Battery voltage
9 (Y)	2	Encoder pulse signal 2	Input	When power window motor operates.	

JMKIA0070GB

POWER WINDOW MAIN SWITCH

< ECU DIAGNOSIS INFORMATION >

[LH&RH FRONT WINDOW ANTI-PINCH]

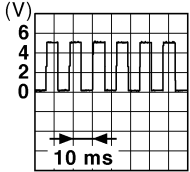
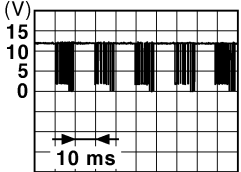
Terminal No.		Description		Condition	Voltage [V] (Approx.)
+	-	Signal name	Input/ Output		
10 (V)	Ground	RAP signal	Input	IGN SW ON	Battery voltage
				Within 45 seconds after ignition switch is turned to OFF.	Battery voltage
				When front LH or RH door is opened during retained power operation.	0
11 (LG)	8	Front door power window motor LH DOWN signal	Output	When front LH switch in power window main switch is operated DOWN.	Battery voltage
13 (G)	2	Encoder pulse signal 1	Input	When power window motor operates.	 <small>JMKIA0070GB</small>
14 (O)	Ground	Power window serial link	Input/ Output	IGN SW ON or power window timer operating.	 <small>JPMIA0013GB</small>
15 (BR)	Ground	Encoder power supply	Output	When ignition switch ON or power window timer operates.	10
17 (B)	Ground	Ground	—	—	0
19 (R)		Battery power supply	Input	—	Battery voltage

Fail Safe

INFOID:000000007253532

FAIL-SAFE CONTROL

Switches to fail-safe control when malfunction is detected in encoder signal that detects up/down speed and direction of door glass. Switches to fail-safe control when error beyond regulation value is detected between the fully closed position and the actual position of the glass.

Error	Error condition
Pulse sensor malfunction	When only one side of pulse signal is being detected for more than the specified value.
Both pulse sensors malfunction	When both pulse signals have not been detected for more than the specified value during glass open/close operation.
Pulse direction malfunction	When the pulse signal that is detected during glass open/close operation detects the opposite condition of power window motor operating direction.
Glass recognition position malfunction 1	When it detects the error between glass fully closed position in power window switch memory and actual fully closed position during glass open/close operation is more than the specified value.

POWER WINDOW MAIN SWITCH

< ECU DIAGNOSIS INFORMATION >

[LH&RH FRONT WINDOW ANTI-PINCH]

Error	Error condition
Glass recognition position malfunction 2	When it detects pulse count more than the value of glass full stroke during glass open/close operation.
Malfunction of not yet updated closed position of glass	When glass open/close operation is continuously performed without fully closing more than the specified value (approximately 10 strokes).

It changes to condition before initialization and the following functions do not operate when switched to fail-safe control:

- Auto-up operation
- Anti-pinch function
- Retained power function

Perform initial operation to recover when switched to fail-safe mode. However, it switches back to fail-safe control when malfunction is found in power window switch or in motor.

A
B
C
D
E
F
G
H
I
J
L
M
N
O
P

PWC

FRONT POWER WINDOW SWITCH

< ECU DIAGNOSIS INFORMATION >

[LH&RH FRONT WINDOW ANTI-PINCH]

FRONT POWER WINDOW SWITCH

Reference Value

INFOID:000000007253533

TERMINAL LAYOUT

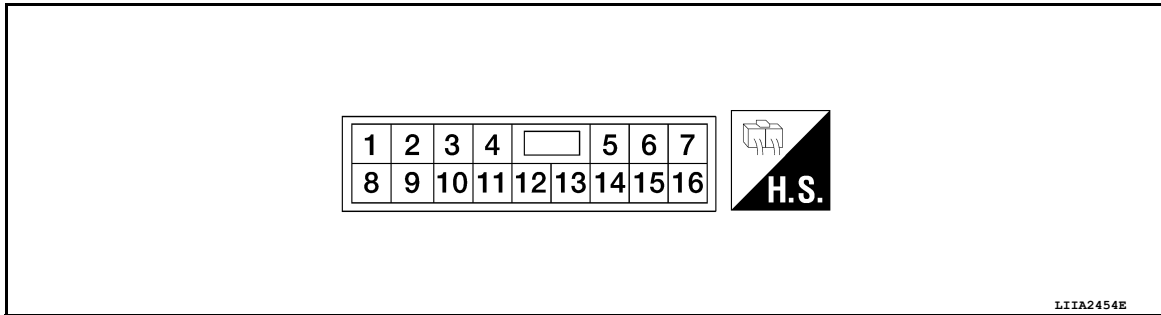

PHYSICAL VALUES

POWER WINDOW AND DOOR LOCK/UNLOCK SWITCH RH

Terminal No.		Description		Condition	Voltage [V] (Approx.)
+	-	Signal name	Input/ Output		
3 (W)	Ground	Encoder ground	—	—	0
4 (BR)	Ground	Encoder power supply	Output	When ignition switch ON or power window timer operates.	10
8 (L)	9	Power window motor UP signal	Output	When power window motor is operated UP.	Battery voltage
9 (LG)	8	Power window motor DOWN signal	Output	When power window motor is operated DOWN.	Battery voltage
10 (P)	Ground	Battery power supply	Input	—	Battery voltage
11 (B)	Ground	Ground	—	—	0
12 (G)	3	Encoder pulse signal 1	Input	When power window motor operates.	<p>The diagram shows a square wave pulse signal. The vertical axis is labeled (V) and ranges from 0 to 6. The horizontal axis is labeled 10 ms. The pulse is a square wave with a period of 10 ms and a peak voltage of approximately 5V.</p>

JMK1A0070GB

FRONT POWER WINDOW SWITCH

< ECU DIAGNOSIS INFORMATION >

[LH&RH FRONT WINDOW ANTI-PINCH]

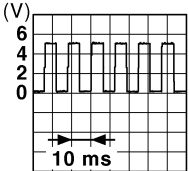
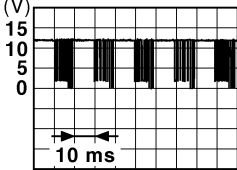
Terminal No.		Description		Condition	Voltage [V] (Approx.)
+	-	Signal name	Input/ Output		
15 (Y)	3	Encoder pulse signal 2	Input	When power window motor operates.	 <p style="text-align: right; font-size: small;">JMKIA0070GB</p>
16 (R)	Ground	Power window serial link	Input/ Output	IGN SW ON or power window timer operating.	 <p style="text-align: right; font-size: small;">JPMIA0013GB</p>

Fail Safe

INFOID:000000007253534

FAIL-SAFE CONTROL

Switches to fail-safe control when malfunction is detected in encoder signal that detects up/down speed and direction of door glass. Switches to fail-safe control when error beyond regulation value is detected between the fully closed position and the actual position of the glass.

Error	Error condition
Pulse sensor malfunction	When only one side of pulse signal is being detected for more than the specified value.
Both pulse sensors malfunction	When both pulse signals have not been detected for more than the specified value during glass open/close operation.
Pulse direction malfunction	When the pulse signal that is detected during glass open/close operation detects the opposite condition of power window motor operating direction.
Glass recognition position malfunction 1	When it detects the error between glass fully closed position in power window switch memory and actual fully closed position during glass open/close operation is more than the specified value.
Glass recognition position malfunction 2	When it detects pulse count more than the value of glass full stroke during glass open/close operation.
Malfunction of not yet updated closed position of glass	When glass open/close operation is continuously performed without fully closing more than the specified value (approximately 10 strokes).

It changes to condition before initialization and the following functions do not operate when switched to fail-safe control:

- Auto-up operation
- Anti-pinch function
- Retained power function

Perform initial operation to recover when switched to fail-safe mode. However, it switches back to fail-safe control when malfunction is found in power window switch or in motor.

BCM (BODY CONTROL MODULE)

< ECU DIAGNOSIS INFORMATION >

[LH&RH FRONT WINDOW ANTI-PINCH]

BCM (BODY CONTROL MODULE)

Reference Value

INFOID:000000007806524

NOTE:

The Signal Tech II Tool (J-50190) can be used to perform the following functions. Refer to the Signal Tech II User Guide for additional information.

- Activate and display TPMS transmitter IDs
- Display tire pressure reported by the TPMS transmitter
- Read TPMS DTCs
- Register TPMS transmitter IDs
- Check Intelligent Key relative signal strength
- Confirm vehicle Intelligent Key antenna signal strength

VALUES ON THE DIAGNOSIS TOOL

Monitor Item	Condition	Value/Status
FR WIPER HI	Other than front wiper switch HI	OFF
	Front wiper switch HI	ON
FR WIPER LOW	Other than front wiper switch LO	OFF
	Front wiper switch LO	ON
FR WASHER SW	Front washer switch OFF	OFF
	Front washer switch ON	ON
FR WIPER INT	Other than front wiper switch INT	OFF
	Front wiper switch INT	ON
FR WIPER STOP	Front wiper is not in STOP position	OFF
	Front wiper is in STOP position	ON
INT VOLUME	Wiper intermittent dial is in a dial position 1 - 7	Wiper intermittent dial position
TURN SIGNAL R	Other than turn signal switch RH	OFF
	Turn signal switch RH	ON
TURN SIGNAL L	Other than turn signal switch LH	OFF
	Turn signal switch LH	ON
TAIL LAMP SW	Other than lighting switch 1ST and 2ND	OFF
	Lighting switch 1ST or 2ND	ON
HI BEAM SW	Other than lighting switch HI	OFF
	Lighting switch HI	ON
HEAD LAMP SW 1	Other than lighting switch 2ND	OFF
	Lighting switch 2ND	ON
HEAD LAMP SW 2	Other than lighting switch 2ND	OFF
	Lighting switch 2ND	ON
PASSING SW	Other than lighting switch PASS	OFF
	Lighting switch PASS	ON
AUTO LIGHT SW	Other than lighting switch AUTO	OFF
	Lighting switch AUTO	ON
FR FOG SW	Front fog lamp switch OFF	OFF
	Front fog lamp switch ON	ON
DOOR SW-DR	Driver door closed	OFF
	Driver door opened	ON
DOOR SW-AS	Passenger door closed	OFF
	Passenger door opened	ON

BCM (BODY CONTROL MODULE)

< ECU DIAGNOSIS INFORMATION >

[LH&RH FRONT WINDOW ANTI-PINCH]

Monitor Item	Condition	Value/Status	
DOOR SW-RR	Rear door RH closed	OFF	A
	Rear door RH opened	ON	
DOOR SW-RL	Rear door LH closed	OFF	B
	Rear door LH opened	ON	
CDL LOCK SW	Other than power door lock switch LOCK	OFF	C
	Power door lock switch LOCK	ON	
CDL UNLOCK SW	Other than power door lock switch UNLOCK	OFF	D
	Power door lock switch UNLOCK	ON	
KEY CYL LK-SW	Other than driver door key cylinder LOCK position	OFF	E
	Driver door key cylinder LOCK position	ON	
KEY CYL UN-SW	Other than driver door key cylinder UNLOCK position	OFF	F
	Driver door key cylinder UNLOCK position	ON	
HAZARD SW	When hazard switch is not pressed	OFF	F
	When hazard switch is pressed	ON	
REAR DEF SW	When rear window defogger switch is pressed	ON	
TR CANCEL SW	Trunk lid opener cancel switch OFF	OFF	G
	Trunk lid opener cancel switch ON	ON	
TR/BD OPEN SW	Trunk lid opener switch OFF	OFF	H
	While the trunk lid opener switch is turned ON	ON	
TRNK/HAT MNTR	Trunk lid closed	OFF	I
	Trunk lid opened	ON	
RKE-LOCK	When LOCK button of Intelligent Key is not pressed	OFF	J
	When LOCK button of Intelligent Key is pressed	ON	
RKE-UNLOCK	When UNLOCK button of Intelligent Key is not pressed	OFF	
	When UNLOCK button of Intelligent Key is pressed	ON	
RKE-TR/BD	When TRUNK OPEN button of Intelligent Key is not pressed	OFF	PWC
	When TRUNK OPEN button of Intelligent Key is pressed	ON	
RKE-PANIC	When PANIC button of Intelligent Key is not pressed	OFF	L
	When PANIC button of Intelligent Key is pressed	ON	
RKE-P/W OPEN	When UNLOCK button of Intelligent Key is not pressed and held	OFF	M
	When UNLOCK button of Intelligent Key is pressed and held	ON	
RKE-MODE CHG	When LOCK/UNLOCK button of Intelligent Key is not pressed and held simultaneously	OFF	N
	When LOCK/UNLOCK button of Intelligent Key is pressed and held simultaneously	ON	
OPTICAL SENSOR	When outside of the vehicle is bright	Close to 5 V	O
	When outside of the vehicle is dark	Close to 0 V	
REQ SW -DR	When front door request switch is not pressed (driver side)	OFF	P
	When front door request switch is pressed (driver side)	ON	
REQ SW -AS	When front door request switch is not pressed (passenger side)	OFF	
	When front door request switch is pressed (passenger side)	ON	
REQ SW -RL	When rear door request switch is not pressed (driver side)	OFF	
	When rear door request switch is pressed (driver side)	ON	
REQ SW -RR	When rear door request switch is not pressed (passenger side)	OFF	
	When rear door request switch is pressed (passenger side)	ON	

BCM (BODY CONTROL MODULE)

< ECU DIAGNOSIS INFORMATION >

[LH&RH FRONT WINDOW ANTI-PINCH]

Monitor Item	Condition	Value/Status
REQ SW -BD/TR	When trunk request switch is not pressed	OFF
	When trunk request switch is pressed	ON
PUSH SW	When engine switch (push switch) is not pressed	OFF
	When engine switch (push switch) is pressed	ON
IGN RLY 2 -F/B	Ignition switch OFF or ACC	OFF
	Ignition switch ON	ON
ACC RLY -F/B	Ignition switch OFF	OFF
	Ignition switch ACC or ON	ON
BRAKE SW 1	When the brake pedal is not depressed	ON
	When the brake pedal is depressed	OFF
DETE/CANCL SW	When selector lever is in P position	OFF
	When selector lever is in any position other than P	ON
SFT PN/N SW	When selector lever is in any position other than P or N	OFF
	When selector lever is in P or N position	ON
UNLK SEN -DR	Driver door UNLOCK status	OFF
	Driver door LOCK status	ON
PUSH SW -IPDM	When engine switch (push switch) is not pressed	OFF
	When engine switch (push switch) is pressed	ON
IGN RLY1 -F/B	Ignition switch OFF or ACC	OFF
	Ignition switch ON	ON
DETE SW -IPDM	When selector lever is in P position	OFF
	When selector lever is in any position other than P	ON
SFT PN -IPDM	When selector lever is in any position other than P or N	OFF
	When selector lever is in P or N position	ON
SFT P -MET	When selector lever is in any position other than P	OFF
	When selector lever is in P position	ON
SFT N -MET	When selector lever is in any position other than N	OFF
	When selector lever is in N position	ON
ENGINE STATE	Engine stopped	STOP
	While the engine stalls	STALL
	At engine cranking	CRANK
	Engine running	RUN
VEH SPEED 1	While driving	Equivalent to speedometer reading
VEH SPEED 2	While driving	Equivalent to speedometer reading
DOOR STAT-DR	Driver door LOCK status	LOCK
	Wait with selective UNLOCK operation (5 seconds)	READY
	Driver door UNLOCK status	UNLK
DOOR STAT-AS	Passenger door LOCK status	LOCK
	Wait with selective UNLOCK operation (5 seconds)	READY
	Passenger door UNLOCK status	UNLK
ID OK FLAG	Ignition switch ACC or ON	RESET
	Ignition switch OFF	SET
PRMT ENG STRT	When the engine start is prohibited	RESET
	When the engine start is permitted	SET

BCM (BODY CONTROL MODULE)

< ECU DIAGNOSIS INFORMATION >

[LH&RH FRONT WINDOW ANTI-PINCH]

Monitor Item	Condition	Value/Status	
KEY SW -SLOT	When Intelligent Key is not inserted into key slot	OFF	A
	When Intelligent Key is inserted into key slot	ON	
RKE OPE COUN1	During the operation of Intelligent Key	Operation frequency of Intelligent Key	B
CONFIRM ID ALL	The key ID that the key slot receives does not accord with any key ID registered to BCM.	YET	
	The key ID that the key slot receives accords with any key ID registered to BCM.	DONE	C
CONFIRM ID4	The key ID that the key slot receives does not accord with the fourth key ID registered to BCM.	YET	
	The key ID that the key slot receives accords with the fourth key ID registered to BCM.	DONE	D
CONFIRM ID3	The key ID that the key slot receives does not accord with the third key ID registered to BCM.	YET	
	The key ID that the key slot receives accords with the third key ID registered to BCM.	DONE	E
CONFIRM ID2	The key ID that the key slot receives does not accord with the second key ID registered to BCM.	YET	F
	The key ID that the key slot receives accords with the second key ID registered to BCM.	DONE	G
CONFIRM ID1	The key ID that the key slot receives does not accord with the first key ID registered to BCM.	YET	
	The key ID that the key slot receives accords with the first key ID registered to BCM.	DONE	H
TP 4	The ID of fourth key is not registered to BCM	YET	
	The ID of fourth key is registered to BCM	DONE	I
TP 3	The ID of third key is not registered to BCM	YET	
	The ID of third key is registered to BCM	DONE	J
TP 2	The ID of second key is not registered to BCM	YET	
	The ID of second key is registered to BCM	DONE	
TP 1	The ID of first key is not registered to BCM	YET	
	The ID of first key is registered to BCM	DONE	PWC
AIR PRESS FL	Ignition switch ON (only when the signal from the transmitter is received)	Air pressure of front LH tire	L
AIR PRESS FR	Ignition switch ON (only when the signal from the transmitter is received)	Air pressure of front RH tire	M
AIR PRESS RR	Ignition switch ON (only when the signal from the transmitter is received)	Air pressure of rear RH tire	
AIR PRESS RL	Ignition switch ON (only when the signal from the transmitter is received)	Air pressure of rear LH tire	N
ID REGST FL1	When ID of front LH tire transmitter is registered	DONE	
	When ID of front LH tire transmitter is not registered	YET	O
ID REGST FR1	When ID of front RH tire transmitter is registered	DONE	
	When ID of front RH tire transmitter is not registered	YET	
ID REGST RR1	When ID of rear RH tire transmitter is registered	DONE	
	When ID of rear RH tire transmitter is not registered	YET	P
ID REGST RL1	When ID of rear LH tire transmitter is registered	DONE	
	When ID of rear LH tire transmitter is not registered	YET	
WARNING LAMP	Tire pressure indicator OFF	OFF	
	Tire pressure indicator ON	ON	

BCM (BODY CONTROL MODULE)

< ECU DIAGNOSIS INFORMATION >

[LH&RH FRONT WINDOW ANTI-PINCH]

Monitor Item	Condition	Value/Status
BUZZER	Tire pressure warning alarm is not sounding	OFF
	Tire pressure warning alarm is sounding	ON

Terminal Layout

INFOID:000000007806525

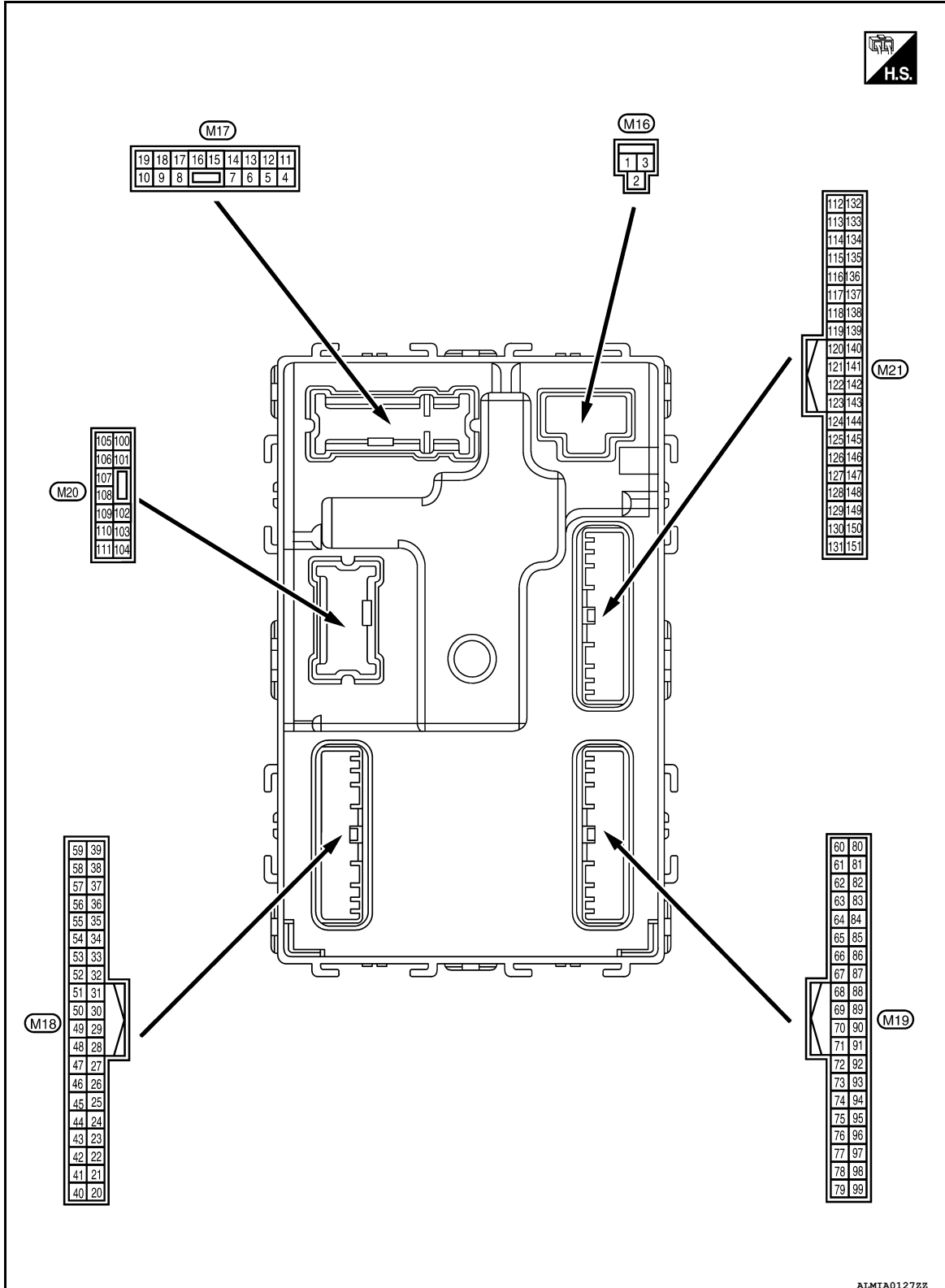

BCM (BODY CONTROL MODULE)

< ECU DIAGNOSIS INFORMATION >

[LH&RH FRONT WINDOW ANTI-PINCH]

Physical Values

INFOID:000000007806526

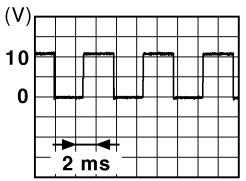
Terminal No. (Wire color)		Description		Condition	Value (Approx.)
		Signal name	Input/ Output		
(+)	(-)				
1 (W/B)	Ground	Battery power supply	Input	Ignition switch OFF	Battery voltage
2 (R/Y)	Ground	Battery power supply output	Output	Ignition switch OFF	Battery voltage
3 (L/W)	Ground	Ignition power supply output	Output	Ignition switch ON	Battery voltage
4 (P/W)	Ground	Interior room lamp power supply	Output	After passing the interior room lamp battery saver operation time	0V
				Any other time after passing the interior room lamp battery saver operation time	Battery voltage
5 (G)	Ground	Front door RH UNLOCK	Output	Front door RH	UNLOCK (actuator is activated) Battery voltage
					Other than UNLOCK (actuator is not activated) 0V
7 (R/W)	Ground	Step lamp	Output	Step lamp	ON 0V
					OFF Battery voltage
8 (V)	Ground	All doors LOCK	Output	All doors	LOCK (actuator is activated) Battery voltage
					Other than LOCK (actuator is not activated) 0V
9 (L)	Ground	Front door LH UNLOCK	Output	Front door LH	UNLOCK (actuator is activated) Battery voltage
					Other than UNLOCK (actuator is not activated) 0V
10 (G)	Ground	Rear door RH and rear door LH UNLOCK	Output	Rear door RH and rear door LH	UNLOCK (actuator is activated) Battery voltage
					Other than UNLOCK (actuator is not activated) 0V
11 (Y/R)	Ground	Battery power supply	Input	Ignition switch OFF	Battery voltage
13 (B)	Ground	Ground	—	Ignition switch ON	0V
14 (GR/W)	Ground	Engine switch (push switch) illumination ground	Input	Tail lamp	OFF 0V
					ON NOTE: When the illumination brightening/dimming level is in the neutral position  JSNIA0010GB
15 (Y/L)	Ground	ACC indicator lamp	Output	Ignition switch	OFF Battery voltage
					ACC or ON 0V

BCM (BODY CONTROL MODULE)

< ECU DIAGNOSIS INFORMATION >

[LH&RH FRONT WINDOW ANTI-PINCH]

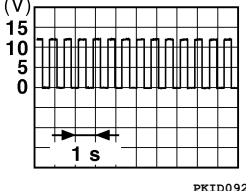
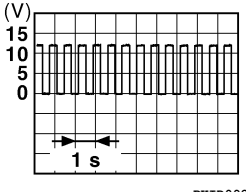
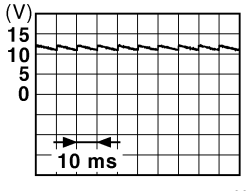
Terminal No. (Wire color)		Description		Condition		Value (Approx.)
(+)	(-)	Signal name	Input/ Output			
17 (G/B)	Ground	Turn signal (RH)	Output	Ignition switch ON	Turn signal switch OFF	0V
					Turn signal switch RH	 <p style="text-align: center;">6.5 V</p>
18 (G/Y)	Ground	Turn signal (LH)	Output	Ignition switch ON	Turn signal switch OFF	0V
					Turn signal switch LH	 <p style="text-align: center;">6.5 V</p>
19 (Y)	Ground	Room lamp timer control	Output	Interior room lamp	OFF	Battery voltage
					ON	0V
21 (P/B)	Ground	Optical sensor signal	Input	Ignition switch ON	When outside of the vehi- cle is bright	Close to 5V
					When outside of the vehi- cle is dark	Close to 0V
24 (R/W)	Ground	Stop lamp switch 1	Input	—	Battery voltage	
26 (O/L)	Ground	Stop lamp switch 2	Input	Stop lamp switch	OFF (brake pedal is re- leased)	0V
					ON (brake pedal is de- pressed)	Battery voltage
27 (O)	Ground	Front door lock as- sembly LH (unlock sensor)	Input	Front door LH	LOCK status	 <p style="text-align: center;">11.8V</p>
					UNLOCK status	0V
29 (Y)	Ground	Key slot switch	Input	When Intelligent Key is inserted into key slot	Battery voltage	
				When Intelligent Key is not inserted into key slot	0V	
31 (G)	Ground	Rear window defog- ger feedback signal	Input	Rear window de- fogger switch	OFF	0V
				ON	Battery voltage	

BCM (BODY CONTROL MODULE)

< ECU DIAGNOSIS INFORMATION >

[LH&RH FRONT WINDOW ANTI-PINCH]

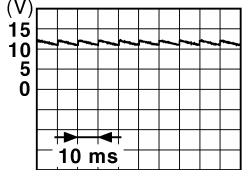
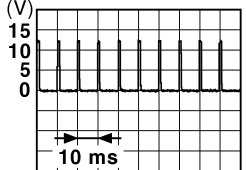
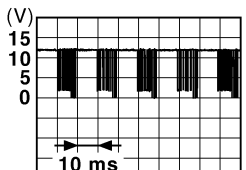
Terminal No. (Wire color)		Description		Condition		Value (Approx.)
(+)	(-)	Signal name	Input/ Output			
32 (R/B)	Ground	Front door RH switch	Input	Front door RH switch	OFF (when front door RH closes)	 11.8 V
					ON (when front door RH opens)	0V
37 (O)	Ground	Trunk lid opener cancel switch	Input	Trunk lid opener cancel switch	CANCEL	 1.1V
					ON	0V
38 (GR/W)	Ground	Rear window defogger ON signal	Input	Rear window defogger switch	OFF	5V
					ON	0V
40 (Y/G)	Ground	Power window serial link	Input/ Output	Ignition switch ON	 10.2V	
				Ignition switch OFF or ACC	0V	
41 (W)	Ground	Engine switch (push switch) illumination	Output	Engine switch (push switch) illumination	ON	5.5V
					OFF	0V
42 (R)	Ground	LOCK indicator lamp	Output	LOCK indicator lamp	ON	0V
					OFF	Battery voltage
45 (P)	Ground	Receiver & sensor ground	Input	Ignition switch ON	0V	
46 (V/W)	Ground	Receiver & sensor power supply output	Output	Ignition switch	OFF	0V
					ACC or ON	5.0V

A
B
C
D
E
F
G
H
I
J
L
M
N
O
P

PWC

BCM (BODY CONTROL MODULE)

< ECU DIAGNOSIS INFORMATION >

[LH&RH FRONT WINDOW ANTI-PINCH]

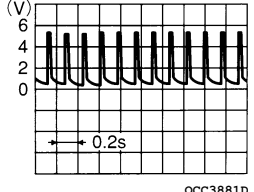
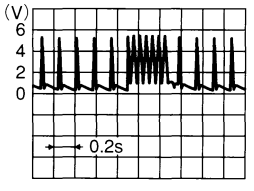
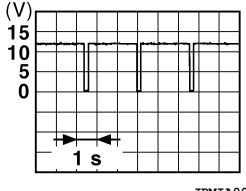
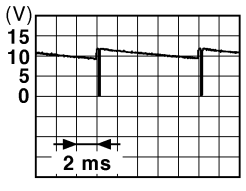
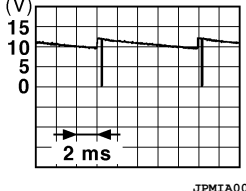
Terminal No. (Wire color)		Description		Condition	Value (Approx.)
(+)	(-)	Signal name	Input/ Output		
47 ¹ (G/O)	Ground	Tire pressure receiver signal	Input/ Output	Ignition switch ON	Standby state  OCC3881D
				When receiving the signal from the transmitter  OCC3880D	
48 (R/G)	Ground	Selector lever transmission range switch signal	Input	Selector lever	P or N position 12.0V
				Except P and N positions	0V
49 (L/O)	Ground	Security indicator signal	Output	Security indicator	ON 0V
				Blinking  JPM1A0014GB 11.3V	
50 (LG/B)	Ground	Combination switch OUTPUT 5	Input	Combination switch (Wiper intermittent dial 4)	All switch OFF 0V
				Lighting switch 1ST	Turn signal switch RH  JPM1A0031GB 10.7V
				Lighting switch high-beam	
				Lighting switch 2ND	
51 (L/W)	Ground	Combination switch OUTPUT 1	Input	Combination switch	All switch OFF (Wiper intermittent dial 4) 0V
				Any of the conditions below with all switch OFF • Wiper intermittent dial 1 • Wiper intermittent dial 2 • Wiper intermittent dial 3 • Wiper intermittent dial 6 • Wiper intermittent dial 7  JPM1A0032GB 10.7V	

BCM (BODY CONTROL MODULE)

< ECU DIAGNOSIS INFORMATION >

[LH&RH FRONT WINDOW ANTI-PINCH]

Terminal No. (Wire color)		Description		Condition	Value (Approx.)	
(+)	(-)	Signal name	Input/ Output			
52 (G/B)	Ground	Combination switch OUTPUT 2	Input	Combination switch	All switch OFF (Wiper intermittent dial 4)	0V
					Front washer switch ON (Wiper intermittent dial 4)	<p style="text-align: right; font-size: small;">JPPIA0033GB</p>
					Any of the conditions below with all switch OFF	
					<ul style="list-style-type: none"> • Wiper intermittent dial 1 • Wiper intermittent dial 5 • Wiper intermittent dial 6 	
53 (LG/ R)	Ground	Combination switch OUTPUT 3	Input	Combination switch (Wiper intermit- tent dial 4)	All switch OFF	0V
					Front wiper switch INT	<p style="text-align: right; font-size: small;">JPPIA0034GB</p>
					Front wiper switch LO	
					Lighting switch AUTO	
54 (G/Y)	Ground	Combination switch OUTPUT 4	Input	Combination switch (Wiper intermit- tent dial 4)	All switch OFF	0V
					Front fog lamp switch ON	<p style="text-align: right; font-size: small;">JPPIA0035GB</p>
					Lighting switch 2ND	
					Lighting switch flash-to- pass	
				Turn signal switch LH	10.7V	
57 ¹ (W)	Ground	Tire pressure warn- ing check switch	Input	—	5V	
58 (SB)	Ground	Front door LH switch	Input	Front door LH switch	OFF (front door LH CLOSE)	<p style="text-align: right; font-size: small;">JPPIA0011GB</p>
					ON (front door LH OPEN)	
59 (G/R)	Ground	Rear window defog- ger relay	Output	Rear window de- fogger	Active	Battery voltage
				Not activated	0V	

A
B
C
D
E
F
G
H
I
J
PWC
L
M
N
O
P

BCM (BODY CONTROL MODULE)

[LH&RH FRONT WINDOW ANTI-PINCH]

< ECU DIAGNOSIS INFORMATION >

Terminal No. (Wire color)		Description		Condition	Value (Approx.)
(+)	(-)	Signal name	Input/ Output		
60 (B/R)	Ground	Front console antenna 2 (-)	Output	Ignition switch OFF	<p>JMKIA0062GB</p>
				When Intelligent Key is not in the passenger compartment	<p>JMKIA0063GB</p>
61 (W/R)	Ground	Center console antenna 2 (+)	Output	Ignition switch OFF	<p>JMKIA0062GB</p>
				When Intelligent Key is not in the passenger compartment	<p>JMKIA0063GB</p>
62 (V)	Ground	Front outside handle RH antenna (-)	Output	When the front door RH request switch is operated with ignition switch OFF	<p>JMKIA0062GB</p>
				When Intelligent Key is not in the antenna detection area	<p>JMKIA0063GB</p>

BCM (BODY CONTROL MODULE)

[LH&RH FRONT WINDOW ANTI-PINCH]

< ECU DIAGNOSIS INFORMATION >

Terminal No. (Wire color)		Description		Condition	Value (Approx.)
(+)	(-)	Signal name	Input/ Output		
63 (P)	Ground	Front outside handle RH antenna (+)	Output	When Intelligent Key is in the antenna detection area	<p>JMKIA0062GB</p>
				When the front door RH request switch is operat- ed with ignition switch OFF	<p>JMKIA0063GB</p>
64 (V)	Ground	Front outside handle LH antenna (-)	Output	When Intelligent Key is in the antenna detection area	<p>JMKIA0062GB</p>
				When the front door LH request switch is operat- ed with ignition switch OFF	<p>JMKIA0063GB</p>
65 (P)	Ground	Front outside handle LH antenna (+)	Output	When Intelligent Key is in the antenna detection area	<p>JMKIA0062GB</p>
				When the front door LH request switch is operat- ed with ignition switch OFF	<p>JMKIA0063GB</p>

A
B
C
D
E
F
G
H
I
J
L
M
N
O
P

PWC

BCM (BODY CONTROL MODULE)

< ECU DIAGNOSIS INFORMATION >

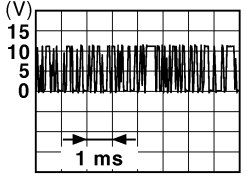
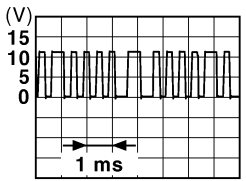
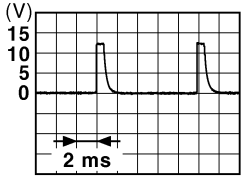
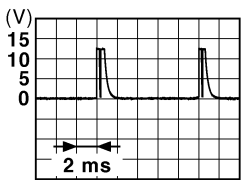
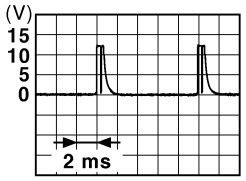

[LH&RH FRONT WINDOW ANTI-PINCH]

Terminal No. (Wire color)		Description		Condition		Value (Approx.)
(+)	(-)	Signal name	Input/ Output			
68 (G/O)	Ground	NATS antenna amp (built in key slot)	Input/ Output	During waiting	Ignition switch is pressed while inserting the Intelli- gent Key into the key slot.	Just after pressing ignition switch. Pointer of tester should move.
69 (O)	Ground	NATS antenna amp (built in key slot)	Input/ Output	During waiting	Ignition switch is pressed while inserting the Intelli- gent Key into the key slot.	Just after pressing ignition switch. Pointer of tester should move.
70 (R/B)	Ground	Ignition relay-2 con- trol	Output	Ignition switch	OFF or ACC ON	0V Battery voltage
71 (L/O)	Ground	Remote keyless entry receiver signal	Input/ Output	During waiting		 <p style="text-align: right; font-size: small;">JMK1A0064GB</p>
				When operating either button on Intelligent Key		 <p style="text-align: right; font-size: small;">JMK1A0065GB</p>
75 (R/Y)	Ground	Combination switch INPUT 5	Output	Combination switch	All switch OFF (Wiper intermittent dial 4)	 <p style="text-align: right; font-size: small;">JPM1A0041GB</p> <p style="text-align: center;">1.4V</p>
					Front fog lamp switch ON (Wiper intermittent dial 4)	 <p style="text-align: right; font-size: small;">JPM1A0037GB</p> <p style="text-align: center;">1.3V</p>
					Any of the conditions below with all switch OFF • Wiper intermittent dial 1 • Wiper intermittent dial 2 • Wiper intermittent dial 6 • Wiper intermittent dial 7	 <p style="text-align: right; font-size: small;">JPM1A0040GB</p> <p style="text-align: center;">1.3V</p>

BCM (BODY CONTROL MODULE)

< ECU DIAGNOSIS INFORMATION >

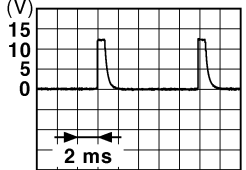
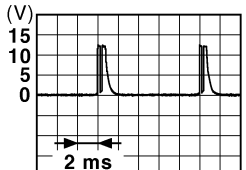
[LH&RH FRONT WINDOW ANTI-PINCH]

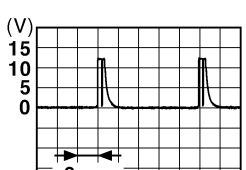
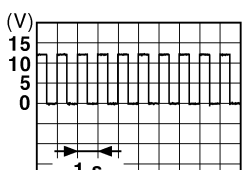
Terminal No. (Wire color)		Description		Condition	Value (Approx.)
(+)	(-)	Signal name	Input/ Output		
76 (R/G)	Ground	Combination switch INPUT 3	Output	Combination switch	All switch OFF (Wiper intermittent dial 4) <div style="text-align: right;">  <p>1.4V</p> </div>
					Lighting switch high-beam (Wiper intermittent dial 4) <div style="text-align: right;">  <p>1.3V</p> </div>
					Lighting switch 2ND (Wiper intermittent dial 4) <div style="text-align: right;">  <p>1.3V</p> </div>
					Any of the conditions below with all switch OFF <ul style="list-style-type: none"> • Wiper intermittent dial 1 • Wiper intermittent dial 2 • Wiper intermittent dial 3 <div style="text-align: right;">  <p>1.3V</p> </div>
78 (P)	Ground	CAN-L	Input/ Output	—	—
79 (L)	Ground	CAN-H	Input/ Output	—	—
80 (R/L)	Ground	Key slot illumination	Output	Key slot illumina- tion	OFF <div style="text-align: right;">0V</div>
				Blinking	<div style="text-align: right;">  <p>6.5V</p> </div>
81 (LG)	Ground	ON indicator lamp	Output	Ignition switch	OFF or ACC <div style="text-align: right;">0V</div>
					ON <div style="text-align: right;">Battery voltage</div>

A
B
C
D
E
F
G
H
I
J
L
M
N
O
P

PWC

BCM (BODY CONTROL MODULE)

< ECU DIAGNOSIS INFORMATION >



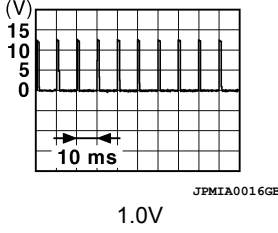
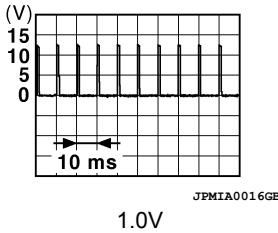

[LH&RH FRONT WINDOW ANTI-PINCH]

Terminal No. (Wire color)		Description		Condition		Value (Approx.)
(+)	(-)	Signal name	Input/ Output			
83 (L)	Ground	ACC relay control	Output	Ignition switch	OFF	0V
					ACC or ON	Battery voltage
84 (Y/R)	Ground	CVT shift selector	Output	—		Battery voltage
87 (G/B)	Ground	Selector lever P position switch	Input	Selector lever	P position	0V
					Any position other than P	Battery voltage
88 (R)	Ground	Front door RH request switch	Input	Front door RH request switch	ON (pressed)	0V
					OFF (not pressed)	
89 (R)	Ground	Front door LH request switch	Input	Front door LH request switch	ON (pressed)	0V
					OFF (not pressed)	
90 (Y)	Ground	Blower fan motor relay control	Output	Ignition switch	OFF or ACC	0V
					ON	Battery voltage
91 (L/R)	Ground	Remote keyless entry receiver power supply	Output	Ignition switch OFF		Battery voltage

BCM (BODY CONTROL MODULE)

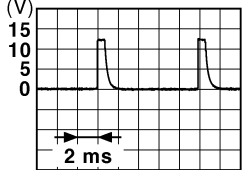
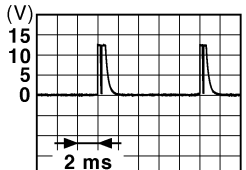
< ECU DIAGNOSIS INFORMATION >

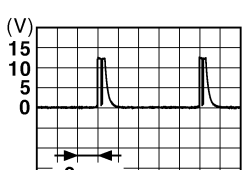
[LH&RH FRONT WINDOW ANTI-PINCH]

Terminal No. (Wire color)		Description		Condition	Value (Approx.)
(+)	(-)	Signal name	Input/ Output		
95 (R/W)	Ground	Combination switch INPUT 1	Output	All switch OFF	 1.4V
				Turn signal switch LH	 1.3V
				Turn signal switch RH	 1.3V
				Front wiper switch LO	 1.3V
				Front washer switch ON	 1.3V

A
B
C
D
E
F
G
H
I
J
L
M
N
O
P

PWC

BCM (BODY CONTROL MODULE)

< ECU DIAGNOSIS INFORMATION >



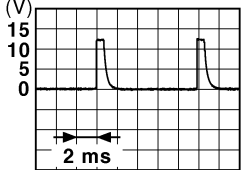
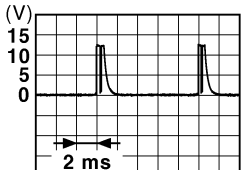
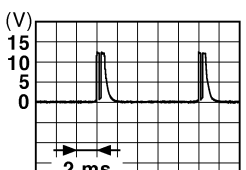
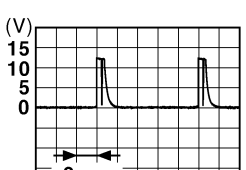

[LH&RH FRONT WINDOW ANTI-PINCH]

Terminal No. (Wire color)		Description		Condition	Value (Approx.)
(+)	(-)	Signal name	Input/ Output		
96 (P/B)	Ground	Combination switch INPUT 4	Output	Combination switch	All switch OFF (Wiper intermittent dial 4) <div style="text-align: right;">  <p style="font-size: small; margin: 0;">JPMIA0041GB</p> <p style="margin: 0;">1.4V</p> </div>
				Lighting switch AUTO (Wiper intermittent dial 4)	Lighting switch AUTO (Wiper intermittent dial 4) <div style="text-align: right;">  <p style="font-size: small; margin: 0;">JPMIA0038GB</p> <p style="margin: 0;">1.3V</p> </div>
				Lighting switch 1ST (Wiper intermittent dial 4)	Lighting switch 1ST (Wiper intermittent dial 4) <div style="text-align: right;">  <p style="font-size: small; margin: 0;">JPMIA0036GB</p> <p style="margin: 0;">1.3V</p> </div>
				Any of the conditions below with all switch OFF	Any of the conditions below with all switch OFF <ul style="list-style-type: none"> • Wiper intermittent dial 1 • Wiper intermittent dial 5 • Wiper intermittent dial 6 <div style="text-align: right;">  <p style="font-size: small; margin: 0;">JPMIA0039GB</p> <p style="margin: 0;">1.3V</p> </div>

BCM (BODY CONTROL MODULE)

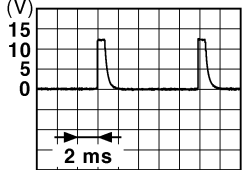
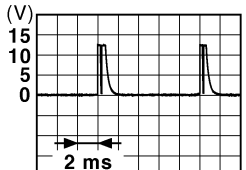
< ECU DIAGNOSIS INFORMATION >

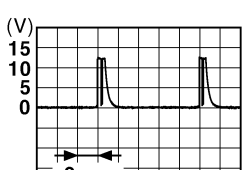
[LH&RH FRONT WINDOW ANTI-PINCH]

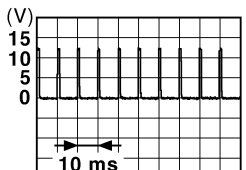
Terminal No. (Wire color)		Description		Condition	Value (Approx.)	
(+)	(-)	Signal name	Input/ Output			
97 (R/B)	Ground	Combination switch INPUT 2	Output	Combination switch (Wiper intermittent dial 4)	All switch OFF	 1.4V
					Lighting switch flash-to-pass	 1.3V
					Lighting switch 2ND	 1.3V
					Front wiper switch INT	 1.3V
					Front wiper switch HI	 1.3V
					Pressed	0 V
98 (G/O)	Ground	Hazard switch	Input	Hazard switch	Not pressed	 1.1V

A
B
C
D
E
F
G
H
I
J
L
M
N
O
P

PWC

BCM (BODY CONTROL MODULE)

< ECU DIAGNOSIS INFORMATION >

[LH&RH FRONT WINDOW ANTI-PINCH]

Terminal No. (Wire color)		Description		Condition	Value (Approx.)	
		Signal name	Input/ Output			
(+)	(-)					
103 (V)	Ground	Trunk lid opening.	Output	Trunk lid	Open (trunk lid opener actuator is activated)	Battery voltage
					Close (trunk lid opener actuator is not activated)	0V
110 (V/W)	Ground	Trunk room lamp	Output	Trunk room lamp	ON	0V
					OFF	Battery voltage
114 (B)	Ground	Trunk room antenna 1 (-)	Output	Ignition switch OFF	When Intelligent Key is in the passenger compartment	<p style="text-align: right; font-size: small;">JMKIA0062GB</p>
					When Intelligent Key is not in the passenger compartment	<p style="text-align: right; font-size: small;">JMKIA0063GB</p>
115 (W)	Ground	Trunk room antenna 1 (+)	Output	Ignition switch OFF	When Intelligent Key is in the passenger compartment	<p style="text-align: right; font-size: small;">JMKIA0062GB</p>
					When Intelligent Key is not in the passenger compartment	<p style="text-align: right; font-size: small;">JMKIA0063GB</p>

BCM (BODY CONTROL MODULE)

< ECU DIAGNOSIS INFORMATION >

[LH&RH FRONT WINDOW ANTI-PINCH]

Terminal No. (Wire color)		Description		Condition	Value (Approx.)
(+)	(-)	Signal name	Input/ Output		
118 (L/O)	Ground	Rear bumper antenna (-)	Output	When the trunk lid request switch is operated with ignition switch OFF	When Intelligent Key is in the antenna detection area
				When Intelligent Key is not in the antenna detection area	When Intelligent Key is not in the antenna detection area
119 (BR/W)	Ground	Rear bumper antenna (+)	Output	When the trunk lid request switch is operated with ignition switch OFF	When Intelligent Key is in the antenna detection area
				When Intelligent Key is not in the antenna detection area	When Intelligent Key is not in the antenna detection area
127 (BR/W)	Ground	Ignition relay (IPDM E/R) control	Output	Ignition switch	OFF or ACC
				OFF	0V
130 (W)	Ground	Trunk room lamp switch	Input	Trunk room lamp switch	OFF (trunk is closed)
					ON (trunk is open)
132 (R)	Ground	Starter motor relay control	Output	Ignition switch ON	When selector lever is in P or N position and the brake is depressed
					When selector lever is in P or N position and the brake is not depressed

A
B
C
D
E
F
G
H
I
J
L
M
N
O
P

PWC

BCM (BODY CONTROL MODULE)

< ECU DIAGNOSIS INFORMATION >

[LH&RH FRONT WINDOW ANTI-PINCH]

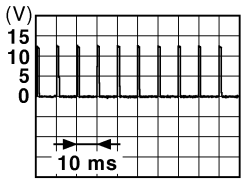
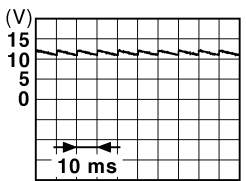
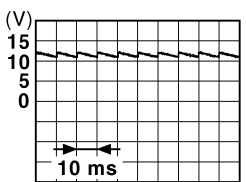
Terminal No. (Wire color)		Description		Condition		Value (Approx.)
		Signal name	Input/ Output			
(+)	(-)					
140 (BR)	Ground	Engine switch (push switch)	Input	Engine switch (push switch)	Pressed	0V
					Not pressed	Battery voltage
141 (BR)	Ground	Trunk request switch	Input	Trunk request switch	ON (pressed)	0V
					OFF (not pressed)	 <p style="text-align: center;">1.0V</p>
144 (GR)	Ground	Request switch buzzer	Output	Request switch buzzer	Sounding	0V
					Not sounding	Battery voltage
147 (L/R)	Ground	Trunk lid opener switch	Input	Trunk lid opener switch	Pressed	0V
					Not pressed	Battery voltage
148 (R/W)	Ground	Rear door RH switch	Input	Rear door RH switch	OFF (when rear door RH closes)	 <p style="text-align: center;">11.8V</p>
					ON (when rear door RH opens)	0V
149 (R/B)	Ground	Rear door LH switch	Input	Rear door LH switch	OFF (when rear door LH closes)	 <p style="text-align: center;">11.8V</p>
					ON (when rear door LH opens)	0V

1 : With low tire pressure monitoring system

Fail Safe

INFOID:000000007806527

Display contents of CONSULT	Fail-safe	Cancellation
B2190: NATS ANTENNA AMP	Inhibit engine cranking	Erase DTC
B2191: DIFFERENCE OF KEY	Inhibit engine cranking	Erase DTC
B2192: ID DISCORD BCM-ECM	Inhibit engine cranking	Erase DTC
B2193: CHAIN OF BCM-ECM	Inhibit engine cranking	Erase DTC
B2195: ANTI-SCANNING	Inhibit engine cranking	Erase DTC

BCM (BODY CONTROL MODULE)

< ECU DIAGNOSIS INFORMATION >

[LH&RH FRONT WINDOW ANTI-PINCH]

Display contents of CONSULT	Fail-safe	Cancellation
B2560: STARTER CONT RELAY	Inhibit engine cranking	500 ms after the following CAN signal communication status has become consistent <ul style="list-style-type: none"> • Starter control relay signal • Starter relay status signal
B2562: LO VOLTAGE	Inhibit engine cranking	100 ms after the power supply voltage increases to more than 8.8 V
B2608: STARTER RELAY	Inhibit engine cranking	500 ms after the following signal communication status becomes consistent <ul style="list-style-type: none"> • Starter motor relay control signal • Starter relay status signal (CAN)
B260A: IGNITION RELAY	Inhibit engine cranking	500 ms after the following conditions are fulfilled <ul style="list-style-type: none"> • IGN relay (IPDM E/R) control signal: OFF (Battery voltage) • Ignition ON signal (CAN to IPDM E/R): OFF (Request signal) • Ignition ON signal (CAN from IPDM E/R): OFF (Condition signal)
B260F: ENG STATE SIG LOST	Maintains the power supply position attained at the time of DTC detection	When any of the following conditions is fulfilled <ul style="list-style-type: none"> • Power position changes to ACC • Receives engine status signal (CAN)
B2617: STARTER RELAY CIRC	Inhibit engine cranking	1 second after the starter motor relay control inside BCM becomes normal
B2618: BCM	Inhibit engine cranking	1 second after the ignition relay (IPDM E/R) control inside BCM becomes normal
B26E1: ENG STATE NO RECIV	Inhibit engine cranking	When any of the following conditions are fulfilled <ul style="list-style-type: none"> • Power position changes to ACC • Receives engine status signal (CAN)

DTC Inspection Priority Chart

INFOID:000000007806528

If some DTCs are displayed at the same time, perform inspections one by one based on the following priority chart.

Priority	DTC
1	<ul style="list-style-type: none"> • B2562: LO VOLTAGE
2	<ul style="list-style-type: none"> • U1000: CAN COMM CIRCUIT • U1010: CONTROL UNIT (CAN)
3	<ul style="list-style-type: none"> • B2190: NATS ANTENNA AMP • B2191: DIFFERENCE OF KEY • B2192: ID DISCORD BCM-ECM • B2193: CHAIN OF BCM-ECM
4	<ul style="list-style-type: none"> • B2553: IGNITION RELAY • B2555: STOP LAMP • B2556: PUSH-BTN IGN SW • B2557: VEHICLE SPEED • B2560: STARTER CONT RELAY • B2601: SHIFT POSITION • B2602: SHIFT POSITION • B2603: SHIFT POSI STATUS • B2604: PNP SWITCH • B2605: PNP SWITCH • B2608: STARTER RELAY • B260A: IGNITION RELAY • B260F: ENG STATE SIG LOST • B2614: ACC RELAY CIRC • B2615: BLOWER RELAY CIRC • B2616: IGN RELAY CIRC • B2617: STARTER RELAY CIRC • B2618: BCM • B261A: PUSH-BTN IGN SW • B26E1: ENG STATE NO RECIV • C1729: VHCL SPEED SIG ERR • U0415: VEHICLE SPEED SIG

BCM (BODY CONTROL MODULE)

< ECU DIAGNOSIS INFORMATION >

[LH&RH FRONT WINDOW ANTI-PINCH]

Priority	DTC
5	<ul style="list-style-type: none"> • C1704: LOW PRESSURE FL • C1705: LOW PRESSURE FR • C1706: LOW PRESSURE RR • C1707: LOW PRESSURE RL • C1708: [NO DATA] FL • C1709: [NO DATA] FR • C1710: [NO DATA] RR • C1711: [NO DATA] RL • C1712: [CHECKSUM ERR] FL • C1713: [CHECKSUM ERR] FR • C1714: [CHECKSUM ERR] RR • C1715: [CHECKSUM ERR] RL • C1716: [PRESSDATA ERR] FL • C1717: [PRESSDATA ERR] FR • C1718: [PRESSDATA ERR] RR • C1719: [PRESSDATA ERR] RL • C1720: [CODE ERR] FL • C1721: [CODE ERR] FR • C1722: [CODE ERR] RR • C1723: [CODE ERR] RL • C1724: [BATT VOLT LOW] FL • C1725: [BATT VOLT LOW] FR • C1726: [BATT VOLT LOW] RR • C1727: [BATT VOLT LOW] RL • C1734: CONTROL UNIT
6	<ul style="list-style-type: none"> • B2622: INSIDE ANTENNA • B2623: INSIDE ANTENNA

DTC Index

INFOID:000000007806529

NOTE:

- Details of time display
- CRNT: Displays when there is a malfunction now or after returning to the normal condition until turning ignition switch OFF → ON again.
- 1 - 39: Displayed if any previous malfunction is present when current condition is normal. It increases 1 → 2 → 3...38 → 39 after returning to the normal condition whenever ignition switch OFF → ON. The counter remains at 39 even if the number of cycles exceeds it. It is counted from 1 again when turning ignition switch OFF → ON after returning to the normal condition if the malfunction is detected again.

CONSULT display	Fail-safe	Intelligent Key warning lamp ON	Tire pressure monitor warning lamp ON	Reference page
No DTC is detected. further testing may be required.	—	—	—	—
U1000: CAN COMM CIRCUIT	—	—	—	BCS-32
U1010: CONTROL UNIT (CAN)	—	—	—	BCS-33
U0415: VEHICLE SPEED SIG	—	—	—	BCS-34
B2190: NATS ANTENNA AMP	×	—	—	SEC-37
B2191: DIFFERENCE OF KEY	×	—	—	SEC-40
B2192: ID DISCORD BCM-ECM	×	—	—	SEC-41
B2193: CHAIN OF BCM-ECM	×	—	—	SEC-42
B2553: IGNITION RELAY	—	—	—	PCS-46
B2555: STOP LAMP	—	—	—	SEC-43
B2556: PUSH-BTN IGN SW	—	×	—	SEC-46
B2557: VEHICLE SPEED	×	×	—	SEC-48
B2560: STARTER CONT RELAY	×	×	—	SEC-49

BCM (BODY CONTROL MODULE)

< ECU DIAGNOSIS INFORMATION >

[LH&RH FRONT WINDOW ANTI-PINCH]

CONSULT display	Fail-safe	Intelligent Key warning lamp ON	Tire pressure monitor warning lamp ON	Reference page
B2562: LOW VOLTAGE	—	—	—	BCS-35
B2601: SHIFT POSITION	×	×	—	SEC-50
B2602: SHIFT POSITION	×	×	—	SEC-53
B2603: SHIFT POSI STATUS	×	×	—	SEC-56
B2604: PNP SWITCH	×	×	—	SEC-59
B2605: PNP SWITCH	×	×	—	SEC-61
B2608: STARTER RELAY	×	×	—	SEC-63
B260A: IGNITION RELAY	×	×	—	PCS-48
B260F: ENG STATE SIG LOST	×	×	—	SEC-65
B2614: ACC RELAY CIRC	—	×	—	PCS-50
B2615: BLOWER RELAY CIRC	—	×	—	PCS-53
B2616: IGN RELAY CIRC	—	×	—	PCS-56
B2617: STARTER RELAY CIRC	×	×	—	SEC-67
B2618: BCM	×	×	—	PCS-59
B261A: PUSH-BTN IGN SW	—	×	—	PCS-60
B2622: INSIDE ANTENNA	—	—	—	DLK-56
B2623: INSIDE ANTENNA	—	—	—	DLK-59
B26E1: ENG STATE NO RES	×	×	—	SEC-66
C1704: LOW PRESSURE FL	—	—	×	WT-43
C1705: LOW PRESSURE FR	—	—	×	WT-43
C1706: LOW PRESSURE RR	—	—	×	WT-43
C1707: LOW PRESSURE RL	—	—	×	WT-43
C1708: [NO DATA] FL	—	—	×	WT-13
C1709: [NO DATA] FR	—	—	×	WT-13
C1710: [NO DATA] RR	—	—	×	WT-13
C1711: [NO DATA] RL	—	—	×	WT-13
C1712: [CHECKSUM ERR] FL	—	—	×	WT-15
C1713: [CHECKSUM ERR] FR	—	—	×	WT-15
C1714: [CHECKSUM ERR] RR	—	—	×	WT-15
C1715: [CHECKSUM ERR] RL	—	—	×	WT-15
C1716: [PRESSDATA ERR] FL	—	—	×	WT-17
C1717: [PRESSDATA ERR] FR	—	—	×	WT-17
C1718: [PRESSDATA ERR] RR	—	—	×	WT-17
C1719: [PRESSDATA ERR] RL	—	—	×	WT-17
C1720: [CODE ERR] FL	—	—	×	WT-15
C1721: [CODE ERR] FR	—	—	×	WT-15
C1722: [CODE ERR] RR	—	—	×	WT-15
C1723: [CODE ERR] RL	—	—	×	WT-15
C1724: [BATT VOLT LOW] FL	—	—	×	WT-15
C1725: [BATT VOLT LOW] FR	—	—	×	WT-15
C1726: [BATT VOLT LOW] RR	—	—	×	WT-15
C1727: [BATT VOLT LOW] RL	—	—	×	WT-15

A

B

C

D

E

F

G

H

I

J

PWC

L

M

N

O

P

BCM (BODY CONTROL MODULE)

< ECU DIAGNOSIS INFORMATION >

[LH&RH FRONT WINDOW ANTI-PINCH]

CONSULT display	Fail-safe	Intelligent Key warning lamp ON	Tire pressure monitor warning lamp ON	Reference page
C1729: VHCL SPEED SIG ERR	—	—	×	WT-19
C1734: CONTROL UNIT	—	—	×	WT-20

POWER WINDOW SYSTEM

[LH&RH FRONT WINDOW ANTI-PINCH]

< WIRING DIAGRAM >

WIRING DIAGRAM

POWER WINDOW SYSTEM

Wiring Diagram

INFOID:000000007253541

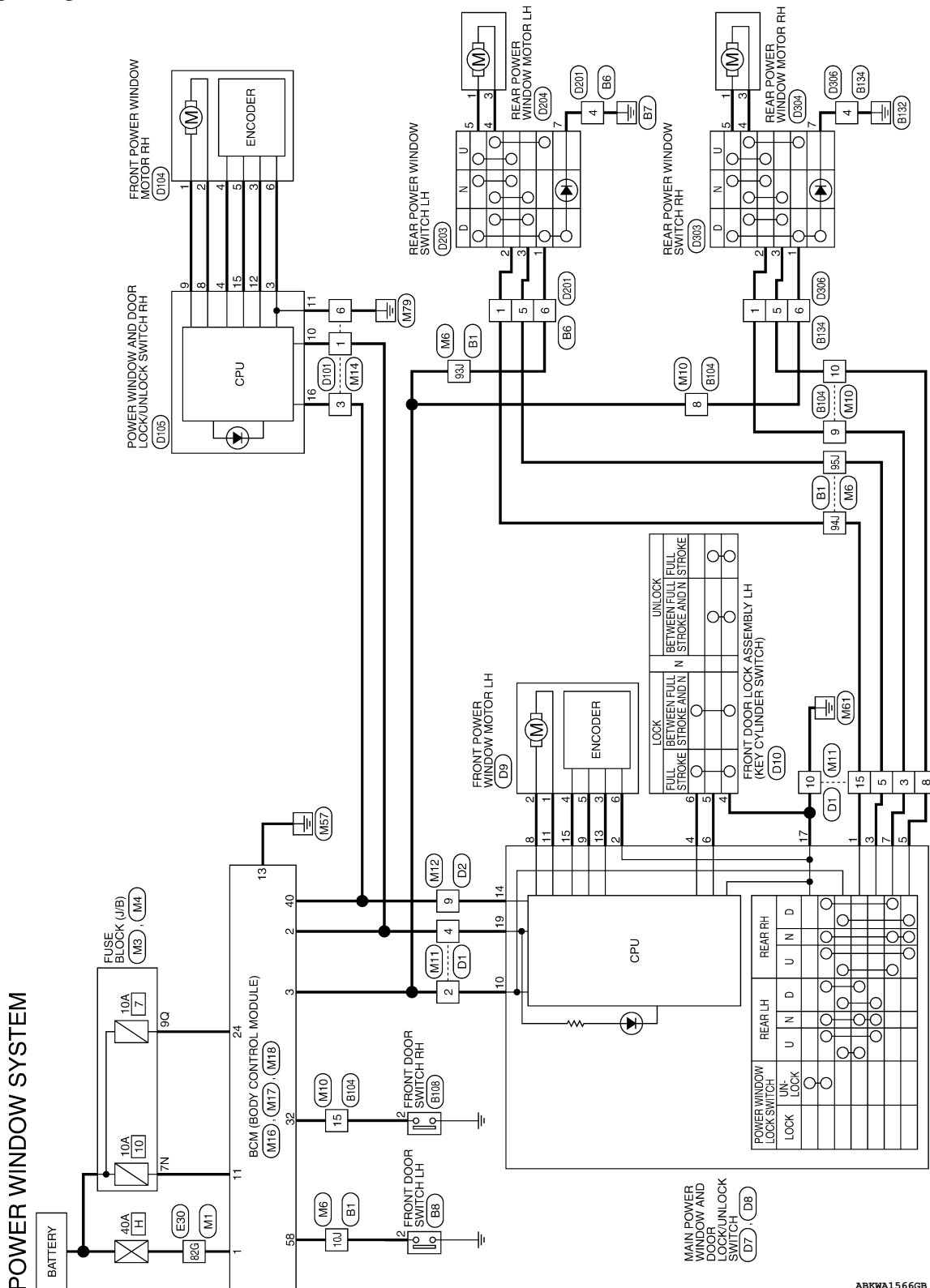

ABKWA1566GB

A
B
C
D
E
F
G
H
I
J
K
L
M
N
O
P

PWC

POWER WINDOW SYSTEM

[LH&RH FRONT WINDOW ANTI-PINCH]

< WIRING DIAGRAM >

POWER WINDOW SYSTEM CONNECTORS

Connector No.	M1
Connector Name	WIRE TO WIRE
Connector Color	WHITE

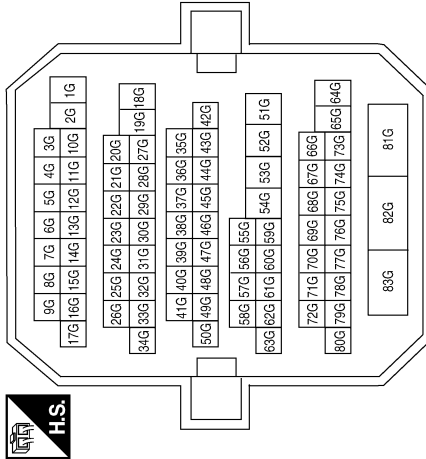

Terminal No.	Color of Wire	Signal Name
82G	W/B	-

Connector No.	M3
Connector Name	FUSE BLOCK (J/B)
Connector Color	WHITE

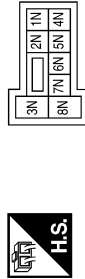

Terminal No.	Color of Wire	Signal Name
7N	Y/R	-

Connector No.	M4
Connector Name	FUSE BLOCK (J/B)
Connector Color	WHITE

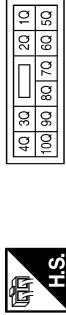

Terminal No.	Color of Wire	Signal Name
9Q	R/W	-

POWER WINDOW SYSTEM

[LH&RH FRONT WINDOW ANTI-PINCH]

< WIRING DIAGRAM >

Connector No.	M10
Connector Name	WIRE TO WIRE
Connector Color	WHITE

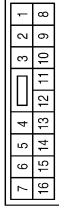

Terminal No.	Color of Wire	Signal Name
8	L/W	-
9	G	-
10	Y/G	-
15	R/B	-

Terminal No.	Color of Wire	Signal Name
10J	SB	-
93J	L/W	-
94J	BR	-
95J	Y/R	-

Connector No.	M6
Connector Name	WIRE TO WIRE
Connector Color	WHITE

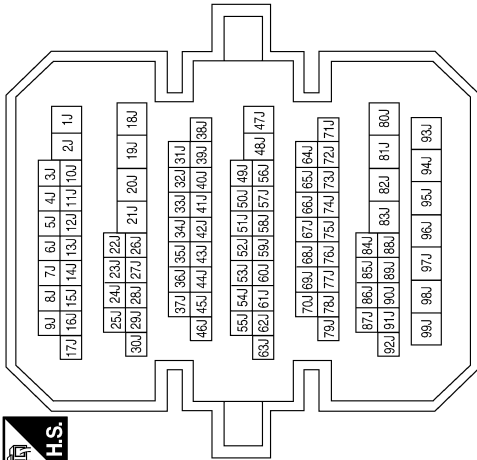

Connector No.	M14
Connector Name	WIRE TO WIRE
Connector Color	WHITE

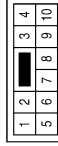

Terminal No.	Color of Wire	Signal Name
1	R/Y	-
3	Y/G	-
6	B	-

Connector No.	M12
Connector Name	WIRE TO WIRE
Connector Color	WHITE

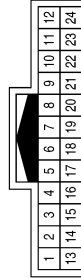

Terminal No.	Color of Wire	Signal Name
9	Y/G	-

Connector No.	M11
Connector Name	WIRE TO WIRE
Connector Color	WHITE



Terminal No.	Color of Wire	Signal Name
2	L/W	-
3	G	-
4	R/Y	-
5	Y/G	-
8	Y/G	-
10	B	-
15	BR	-

ABKIA3333GB

A
B
C
D
E
F
G
H
I
J
L
M
N
O
P



PWC

POWER WINDOW SYSTEM

[LH&RH FRONT WINDOW ANTI-PINCH]



< WIRING DIAGRAM >

Connector No.	M16
Connector Name	BCM (BODY CONTROL MODULE)
Connector Color	BLACK



1	2	3	4	5	6	7	8	9	10
11	12	13	14	15	16	17	18	19	

Connector No.	M17
Connector Name	BCM (BODY CONTROL MODULE)
Connector Color	WHITE

4	5	6	7	8	9	10		
11	12	13	14	15	16	17	18	19

Connector No.	M18
Connector Name	BCM (BODY CONTROL MODULE)
Connector Color	GREEN

39	38	37	36	35	34	33	32	31	30	29	28	27	26	25	24	23	22	21	20
59	58	57	56	55	54	53	52	51	50	49	48	47	46	45	44	43	42	41	40

Terminal No.	Color of Wire	Signal Name
24	R/W	BRAKE SW 1
32	R/B	AS DOOR SW 1
40	Y/G	PW K-LINE
58	SB	DR DOOR SW

Terminal No.	Color of Wire	Signal Name
11	Y/R	BAT BCM FUSE
13	B	GND1

Terminal No.	Color of Wire	Signal Name
1	W/B	BATT (F/L)
2	R/Y	P/W POWER SUPPLY PERM
3	L/W	P/W POWER SUPPLY IGN

Terminal No.	Color of Wire	Signal Name
10J	SB	-
93J	R	-
94J	P	-
95J	SB	-

Terminal No.	Color of Wire	Signal Name
B1	WIRE TO WIRE	
	WHITE	

Terminal No.	Color of Wire	Signal Name
E30	WIRE TO WIRE	
	WHITE	

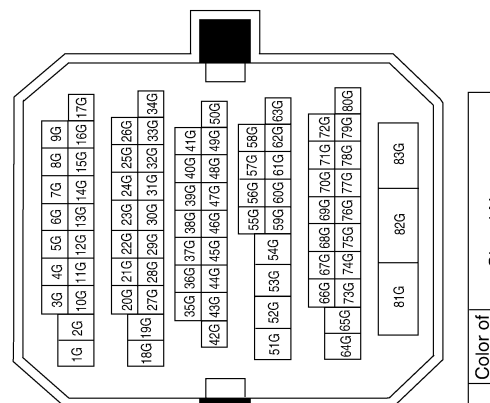
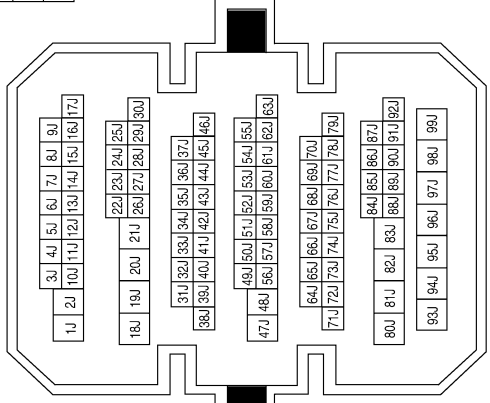

ABK1A1827GB

POWER WINDOW SYSTEM

[LH&RH FRONT WINDOW ANTI-PINCH]

< WIRING DIAGRAM >

Connector No.	B104
Connector Name	WIRE TO WIRE
Connector Color	WHITE



1	2	3	4	5	6	7		
8	9	10	11	12	13	14	15	16

Terminal No.	Color of Wire	Signal Name
8	R	-
9	P	-
10	SB	-
15	GR	-

Connector No.	B8
Connector Name	FRONT DOOR SWITCH LH
Connector Color	WHITE



1	2	3
---	---	---

Terminal No.	Color of Wire	Signal Name
2	SB	-

Connector No.	B6
Connector Name	WIRE TO WIRE
Connector Color	WHITE



1	2	3	4		
5	6	7	8	9	10

Terminal No.	Color of Wire	Signal Name
1	P	-
4	B	-
5	SB	-
6	R	-

Connector No.	D1
Connector Name	WIRE TO WIRE
Connector Color	WHITE



7	6	5	4	3	2	1		
16	15	14	13	12	11	10	9	8

Terminal No.	Color of Wire	Signal Name
2	V	-
3	P	-
4	R	-
5	Y	-
8	SB	-
10	B	-
15	W	-

Connector No.	B134
Connector Name	WIRE TO WIRE
Connector Color	WHITE



1	2	3	4		
5	6	7	8	9	10

Terminal No.	Color of Wire	Signal Name
1	P	-
4	B	-
5	SB	-
6	R	-

Connector No.	B108
Connector Name	FRONT DOOR SWITCH RH
Connector Color	WHITE



1	2	3
---	---	---

Terminal No.	Color of Wire	Signal Name
2	GR	-

ABK1A1828GB

A
B
C
D
E
F
G
H
I
J
L
M
N
O
P

PWC

POWER WINDOW SYSTEM

[LH&RH FRONT WINDOW ANTI-PINCH]

< WIRING DIAGRAM >

Connector No.	D2
Connector Name	WIRE TO WIRE
Connector Color	WHITE

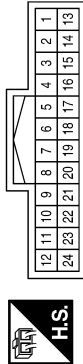

Terminal No.	Color of Wire	Signal Name
9	O	-

Connector No.	D7
Connector Name	MAIN POWER WINDOW AND DOOR LOCK/UNLOCK SWITCH
Connector Color	WHITE

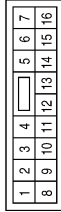

Terminal No.	Color of Wire	Signal Name
1	W	RL UP
2	GR	ENCODER GND
3	Y	RL DOWN
4	L	LOCK

Terminal No.	Color of Wire	Signal Name
5	SB	RR DOWN
6	R	UNLOCK
7	P	RR UP
8	L	AS UP
9	Y	ENCODER SIG1
10	V	IGN
11	LG	AS DOWN
12	-	-
13	G	ENCODER SIG2
14	O	COM
15	BR	ENCODER POWER
16	-	-

Connector No.	D8
Connector Name	MAIN POWER WINDOW AND DOOR LOCK/UNLOCK SWITCH
Connector Color	WHITE

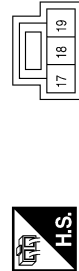

Terminal No.	Color of Wire	Signal Name
17	B	GND
18	-	-
19	R	BAT

Connector No.	D9
Connector Name	FRONT POWER WINDOW MOTOR LH
Connector Color	WHITE



Terminal No.	Color of Wire	Signal Name
1	LG	-
2	L	-
3	G	-
4	BR	-
5	Y	-
6	GR	-

Connector No.	D10
Connector Name	FRONT DOOR LOCK ASSEMBLY LH
Connector Color	GRAY

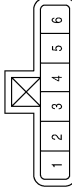

Terminal No.	Color of Wire	Signal Name
4	B	-
5	R	-
6	L	-

ABK1A1829GB

POWER WINDOW SYSTEM

[LH&RH FRONT WINDOW ANTI-PINCH]

< WIRING DIAGRAM >

Connector No.	D105
Connector Name	POWER WINDOW AND DOOR LOCK/UNLOCK SWITCH RH
Connector Color	WHITE

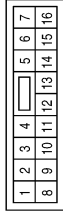

Terminal No.	Color of Wire	Signal Name
3	W	GND
4	BR	ENCODER POWER
8	L	UP
9	LG	DOWN
10	P	BAT
11	B	GND
12	G	ENCODER SIG2
15	Y	ENCODER SIG1
16	R	COM



Connector No.	D204
Connector Name	REAR POWER WINDOW MOTOR LH
Connector Color	GREEN

Terminal No.	Color of Wire	Signal Name
1	L	-
3	LG	-

Connector No.	D104
Connector Name	FRONT POWER WINDOW MOTOR RH
Connector Color	WHITE



Terminal No.	Color of Wire	Signal Name
1	LG	-
2	L	-
3	G	-
4	BR	-
5	Y	-
6	W	-

Connector No.	D203
Connector Name	REAR POWER WINDOW SWITCH LH
Connector Color	WHITE

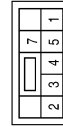

Terminal No.	Color of Wire	Signal Name
1	R	-
2	P	-
3	SB	-
4	LG	-
5	L	-
7	B	-

Connector No.	D101
Connector Name	WIRE TO WIRE
Connector Color	WHITE

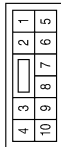

Terminal No.	Color of Wire	Signal Name
1	P	-
3	R	-
6	B	-

Connector No.	D201
Connector Name	WIRE TO WIRE
Connector Color	WHITE



Terminal No.	Color of Wire	Signal Name
1	P	-
4	B	-
5	SB	-
6	R	-

ABKIA3334GB

A
B
C
D
E
F
G
H
I
J
K
L
M
N
O
P

PWC

POWER WINDOW SYSTEM

[LH&RH FRONT WINDOW ANTI-PINCH]

< WIRING DIAGRAM >

Connector No.	D306
Connector Name	WIRE TO WIRE
Connector Color	WHITE

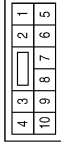

Terminal No.	Color of Wire	Signal Name
1	P	-
4	B	-
5	SB	-
6	R	-

Connector No.	D304
Connector Name	REAR POWER WINDOW MOTOR RH
Connector Color	GREEN



Terminal No.	Color of Wire	Signal Name
1	L	-
3	LG	-

Connector No.	D303
Connector Name	REAR POWER WINDOW SWITCH RH
Connector Color	WHITE

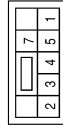

Terminal No.	Color of Wire	Signal Name
1	R	-
2	P	-
3	SB	-
4	LG	-
5	L	-
7	B	-

ABKIA3335GB

SYMPTOM DIAGNOSIS

NONE OF THE POWER WINDOWS CAN BE OPERATED USING ANY SWITCH

Diagnosis Procedure

INFOID:000000007253542

1. CHECK BCM POWER SUPPLY AND GROUND CIRCUIT

Check BCM power supply and ground circuit. Refer to [BCS-36. "Diagnosis Procedure"](#).

Is the inspection result normal?

YES >> GO TO 2

NO >> Repair or replace the malfunctioning parts.

2. CHECK MAIN POWER WINDOW AND DOOR LOCK/UNLOCK SWITCH POWER SUPPLY AND GROUND CIRCUIT

Check main power window and door lock/unlock switch power supply and ground circuit. Refer to [PWC-17. "POWER WINDOW MAIN SWITCH : Diagnosis Procedure"](#).

Is the inspection result normal?

YES >> Check intermittent incident. Refer to [GI-39. "Intermittent Incident"](#).

NO >> Repair or replace the malfunctioning parts.

A
B
C
D
E
F
G
H
I
J
L
M
N
O
P

PWC

DRIVER SIDE POWER WINDOW ALONE DOES NOT OPERATE

< SYMPTOM DIAGNOSIS >

[LH&RH FRONT WINDOW ANTI-PINCH]

DRIVER SIDE POWER WINDOW ALONE DOES NOT OPERATE

Diagnosis Procedure

INFOID:000000007253543

1. CHECK FRONT POWER WINDOW MOTOR LH

Check front power window motor LH. Refer to [PWC-25, "DRIVER SIDE : Component Function Check"](#).

Is the inspection result normal?

YES >> Inspection End.

NO >> Check intermittent incident. Refer to [GI-39, "Intermittent Incident"](#).

FRONT PASSENGER SIDE POWER WINDOW ALONE DOES NOT OPERATE

< SYMPTOM DIAGNOSIS >

[LH&RH FRONT WINDOW ANTI-PINCH]

FRONT PASSENGER SIDE POWER WINDOW ALONE DOES NOT OPERATE

Diagnosis Procedure

INFOID:000000007253544

1. CHECK FRONT POWER WINDOW MOTOR RH CIRCUIT

Check front power window motor RH circuit. Refer to [PWC-27, "PASSENGER SIDE : Component Function Check"](#).

Is the inspection result normal?

YES >> Inspection End.

NO >> Check intermittent incident. Refer to [GI-39, "Intermittent Incident"](#).

A
B
C
D
E
F
G
H
I
J
L
M
N
O
P

PWC

REAR LH SIDE POWER WINDOW ALONE DOES NOT OPERATE

< SYMPTOM DIAGNOSIS >

[LH&RH FRONT WINDOW ANTI-PINCH]

REAR LH SIDE POWER WINDOW ALONE DOES NOT OPERATE

Diagnosis Procedure

INFOID:000000007253545

1. CHECK REAR POWER WINDOW MOTOR LH

Check rear power window motor LH. Refer to [PWC-29, "REAR LH : Component Function Check"](#).

Is the inspection result normal?

YES >> Inspection End.

NO >> Check intermittent incident. Refer to [GI-39, "Intermittent Incident"](#).

REAR RH SIDE POWER WINDOW ALONE DOES NOT OPERATE

< SYMPTOM DIAGNOSIS >

[LH&RH FRONT WINDOW ANTI-PINCH]

REAR RH SIDE POWER WINDOW ALONE DOES NOT OPERATE

Diagnosis Procedure

INFOID:000000007253546

1. CHECK REAR POWER WINDOW MOTOR RH

Check rear power window motor RH. Refer to [PWC-30, "REAR RH : Component Function Check"](#).

Is the inspection result normal?

YES >> Inspection End.

NO >> Check intermittent incident. Refer to [GI-39, "Intermittent Incident"](#).

A
B
C
D
E
F
G
H
I
J
L
M
N
O
P

PWC

ANTI-PINCH SYSTEM DOES NOT OPERATE NORMALLY (DRIVER SIDE)

< SYMPTOM DIAGNOSIS >

[LH&RH FRONT WINDOW ANTI-PINCH]

ANTI-PINCH SYSTEM DOES NOT OPERATE NORMALLY (DRIVER SIDE)

Diagnosis Procedure

INFOID:000000007253547

1. PERFORM INITIALIZATION PROCEDURE

Perform initialization procedure. Refer to [PWC-7, "ADDITIONAL SERVICE WHEN REPLACING CONTROL UNIT : Special Repair Requirement"](#).

Is the inspection result normal?

YES >> Inspection End.

NO >> GO TO 2

2. CHECK ENCODER CIRCUIT

Check encoder circuit. Refer to [PWC-33, "DRIVER SIDE : Component Function Check"](#).

Is the inspection result normal?

YES >> Check intermittent incident. Refer to [GI-39, "Intermittent Incident"](#).

NO >> Repair or replace malfunctioning parts.

ANTI-PINCH SYSTEM DOES NOT OPERATE NORMALLY (PASSENGER SIDE)
< SYMPTOM DIAGNOSIS > **[LH&RH FRONT WINDOW ANTI-PINCH]**

ANTI-PINCH SYSTEM DOES NOT OPERATE NORMALLY (PASSENGER SIDE)

Diagnosis Procedure

INFOID:000000007253548

1. PERFORM INITIALIZATION PROCEDURE

Perform initialization procedure. Refer to [PWC-7, "ADDITIONAL SERVICE WHEN REPLACING CONTROL UNIT : Special Repair Requirement"](#).

Is the inspection result normal?

YES >> Inspection End.

NO >> GO TO 2

2. CHECK ENCODER CIRCUIT

Check encoder circuit. Refer to [PWC-36, "PASSENGER SIDE : Component Function Check"](#).

Is the inspection result normal?

YES >> Check intermittent incident. Refer to [GI-39, "Intermittent Incident"](#).

NO >> Repair or replace the malfunctioning parts.

A
B
C
D
E
F
G
H
I
J
L
M
N
O
P

PWC

AUTO OPERATION DOES NOT OPERATE BUT MANUAL OPERATES NORMALLY (DRIVER SIDE)

< SYMPTOM DIAGNOSIS >

[LH&RH FRONT WINDOW ANTI-PINCH]

AUTO OPERATION DOES NOT OPERATE BUT MANUAL OPERATES NORMALLY (DRIVER SIDE)

Diagnosis Procedure

INFOID:000000007253549

1. PERFORM INITIALIZATION PROCEDURE

Perform initialization procedure. Refer to [PWC-7, "ADDITIONAL SERVICE WHEN REPLACING CONTROL UNIT : Special Repair Requirement"](#).

Is the inspection result normal?

YES >> Inspection End.

NO >> GO TO 2

2. CHECK ENCODER

Check encoder. Refer to [PWC-33, "DRIVER SIDE : Component Function Check"](#).

Is the inspection result normal?

YES >> Check intermittent incident. Refer to [GI-39, "Intermittent Incident"](#).

NO >> Repair or replace the malfunctioning parts.

AUTO OPERATION DOES NOT OPERATE BUT MANUAL OPERATES NORMALLY (PASSENGER SIDE)

< SYMPTOM DIAGNOSIS >

[LH&RH FRONT WINDOW ANTI-PINCH]

AUTO OPERATION DOES NOT OPERATE BUT MANUAL OPERATES NORMALLY (PASSENGER SIDE)

Diagnosis Procedure

INFOID:000000007253550

1. PERFORM INITIALIZATION PROCEDURE

Perform initialization procedure. Refer to [PWC-7, "ADDITIONAL SERVICE WHEN REPLACING CONTROL UNIT : Special Repair Requirement"](#).

Is the inspection result normal?

YES >> Inspection End.

NO >> GO TO 2

2. CHECK ENCODER

Check encoder. Refer to [PWC-36, "PASSENGER SIDE : Component Function Check"](#).

Is the inspection result normal?

YES >> Check intermittent incident. Refer to [GI-39, "Intermittent Incident"](#).

NO >> Repair or replace the malfunctioning parts.

A
B
C
D
E
F
G
H
I
J
L
M
N
O
P

PWC

POWER WINDOW RETAINED POWER OPERATION DOES NOT OPERATE PROPERLY

< SYMPTOM DIAGNOSIS >

[LH&RH FRONT WINDOW ANTI-PINCH]

POWER WINDOW RETAINED POWER OPERATION DOES NOT OPERATE PROPERLY

Diagnosis Procedure

INFOID:000000007253551

1. CHECK FRONT DOOR SWITCH

Check front door switch. Refer to [PWC-39, "Component Function Check"](#).

Is the inspection result normal?

- YES >> Check intermittent incident. Refer to [GI-39, "Intermittent Incident"](#).
- NO >> Repair or replace malfunctioning parts.

DOES NOT OPERATE BY KEY CYLINDER SWITCH

< SYMPTOM DIAGNOSIS >

[LH&RH FRONT WINDOW ANTI-PINCH]

DOES NOT OPERATE BY KEY CYLINDER SWITCH

Diagnosis Procedure

INFOID:000000007253552

1. CHECK FRONT DOOR LOCK ASSEMBLY LH (KEY CYLINDER SWITCH)

Check front door lock assembly LH (key cylinder switch). Refer to [PWC-42, "Diagnosis Procedure"](#).

Is the inspection result normal?

YES >> Check intermittent incident. Refer to [GI-39, "Intermittent Incident"](#).

NO >> Repair or replace malfunctioning parts.

A
B
C
D
E
F
G
H
I
J
L
M
N
O
P

PWC

KEYLESS POWER WINDOW DOWN DOES NOT OPERATE

< SYMPTOM DIAGNOSIS >

[LH&RH FRONT WINDOW ANTI-PINCH]

KEYLESS POWER WINDOW DOWN DOES NOT OPERATE

Diagnosis Procedure

INFOID:000000007253553

1. CHECK INTELLIGENT KEY FUNCTION

Check Intelligent Key function. Refer to [DLK-111, "Component Function Check"](#).

Is the inspection result normal?

YES >> Check intermittent incident. Refer to [GI-39, "Intermittent Incident"](#).

NO >> Replace BCM. Refer to [BCS-80, "Removal and Installation"](#).

POWER WINDOW LOCK SWITCH DOES NOT FUNCTION

< SYMPTOM DIAGNOSIS >

[LH&RH FRONT WINDOW ANTI-PINCH]

POWER WINDOW LOCK SWITCH DOES NOT FUNCTION

Diagnosis Procedure

INFOID:000000007253554

1. CHECK POWER WINDOW LOCK SWITCH

Check power window lock switch. Refer to [PWC-49, "Component Function Check"](#).

Is the inspection result normal?

- YES >> Check intermittent incident. Refer to [GI-39, "Intermittent Incident"](#).
- NO >> Repair or replace malfunctioning parts.

A
B
C
D
E
F
G
H
I
J
L
M
N
O
P

PWC

PRECAUTION

PRECAUTIONS

Precaution for Supplemental Restraint System (SRS) "AIR BAG" and "SEAT BELT PRE-TENSIONER"

INFOID:000000007253555

The Supplemental Restraint System such as "AIR BAG" and "SEAT BELT PRE-TENSIONER", used along with a front seat belt, helps to reduce the risk or severity of injury to the driver and front passenger for certain types of collision. This system includes seat belt switch inputs and dual stage front air bag modules. The SRS system uses the seat belt switches to determine the front air bag deployment, and may only deploy one front air bag, depending on the severity of a collision and whether the front occupants are belted or unbelted. Information necessary to service the system safely is included in the SR and SB section of this Service Manual.

WARNING:

- **To avoid rendering the SRS inoperative, which could increase the risk of personal injury or death in the event of a collision which would result in air bag inflation, all maintenance must be performed by an authorized NISSAN/INFINITI dealer.**
- **Improper maintenance, including incorrect removal and installation of the SRS, can lead to personal injury caused by unintentional activation of the system. For removal of Spiral Cable and Air Bag Module, see the SR section.**
- **Do not use electrical test equipment on any circuit related to the SRS unless instructed to in this Service Manual. SRS wiring harnesses can be identified by yellow and/or orange harnesses or harness connectors.**

PRECAUTIONS WHEN USING POWER TOOLS (AIR OR ELECTRIC) AND HAMMERS

WARNING:

- **When working near the Airbag Diagnosis Sensor Unit or other Airbag System sensors with the Ignition ON or engine running, DO NOT use air or electric power tools or strike near the sensor(s) with a hammer. Heavy vibration could activate the sensor(s) and deploy the air bag(s), possibly causing serious injury.**
- **When using air or electric power tools or hammers, always switch the Ignition OFF, disconnect the battery, and wait at least 3 minutes before performing any service.**

Precaution for Work

INFOID:000000007253556

- When removing or disassembling each component, be careful not to damage or deform it. If a component may be subject to interference, be sure to protect it with a shop cloth.
- When removing (disengaging) components with a screwdriver or similar tool, be sure to wrap the component with a shop cloth or vinyl tape to protect it.
- Protect the removed parts with a shop cloth and prevent them from being dropped.
- Replace a deformed or damaged clip.
- If a part is specified as a non-reusable part, always replace it with new one.
- Be sure to tighten bolts and nuts securely to the specified torque.
- After installation is complete, be sure to check that each part works properly.
- Follow the steps below to clean components.
 - Water soluble dirt: Dip a soft cloth into lukewarm water, and wring the water out of the cloth to wipe the dirty area.
Then rub with a soft and dry cloth.
 - Oily dirt: Dip a soft cloth into lukewarm water with mild detergent (concentration: within 2 to 3%), and wipe the dirty area.
Then dip a cloth into fresh water, and wring the water out of the cloth to wipe the detergent off. Then rub with a soft and dry cloth.
- Do not use organic solvent such as thinner, benzene, alcohol, or gasoline.
- For genuine leather seats, use a genuine leather seat cleaner.

PREPARATION

< PREPARATION >

[LH&RH FRONT WINDOW ANTI-PINCH]

PREPARATION

PREPARATION

Special Service Tool

INFOID:000000007253557

The actual shapes of Kent-Moore tools may differ from those of special service tools illustrated here.

Tool number (Kent-Moore No.) Tool name	Description
— (J-46534) Trim tool set	Removing trim components

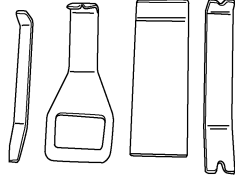

AWJIA0483ZZ

A
B
C
D
E
F
G
H
I
J

PWC

L
M
N
O
P

PERIODIC MAINTENANCE

PRE-INSPECTION FOR DIAGNOSTIC

Basic Inspection

INFOID:000000007253558

BASIC INSPECTION

1.INSPECTION START

1. Check the service history.
2. Check the following parts.
 - Fuse/circuit breaker blown.
 - Poor connection, open or short circuit of harness connector.
 - Battery voltage.

Is the inspection result normal?

- YES >> Inspection End.
NO >> Repair or replace the malfunctioning parts.

MAIN POWER WINDOW AND DOOR LOCK/UNLOCK SWITCH

< REMOVAL AND INSTALLATION >

[LH&RH FRONT WINDOW ANTI-PINCH]

REMOVAL AND INSTALLATION

MAIN POWER WINDOW AND DOOR LOCK/UNLOCK SWITCH

Removal and Installation

INFOID:000000007253559

REMOVAL

1. Remove the front door grip cover. Refer to [INT-18, "Removal and Installation"](#).
2. Using a suitable tool, remove the clip (A) from the door grip.

CAUTION:

Wrap a cloth around suitable tool to protect components from damage.

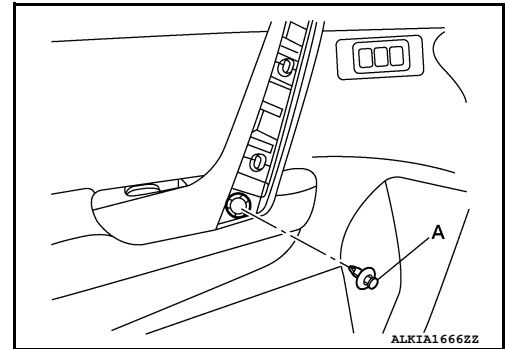

3. Using a suitable tool, release the metal clip and lift the main power window and door lock/unlock switch (2) and finisher (1) as an assembly starting from the rear, pull upward to remove it from the front door finisher.

□: Metal clip

CAUTION:

Wrap a cloth around suitable tool to protect components from damage.

4. Disconnect the harness connector from the main power window and door lock/unlock switch.
5. Release the pawls on each side to separate the switch finisher (1) from the main power window and door lock/unlock switch (2).

○: Pawl

CAUTION:

Do not damage the pawl of the switch finisher.

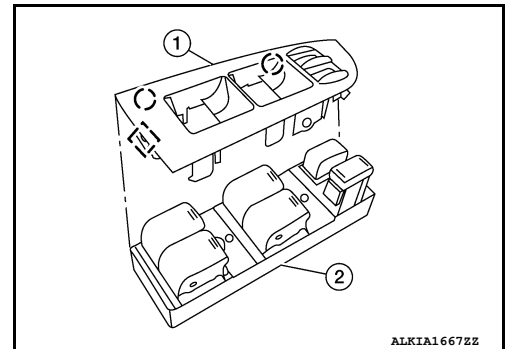

INSTALLATION

Installation is in the reverse order of removal.

NOTE:

Whenever the main power window and door lock/unlock switch is disconnected from the harness connector, it is necessary to perform the Initialization procedure. Refer to [PWC-7, "ADDITIONAL SERVICE WHEN REPLACING CONTROL UNIT : Special Repair Requirement"](#).

A
B
C
D
E
F
G
H
I
J
L
M
N
O
P

PWC

POWER WINDOW AND DOOR LOCK/UNLOCK SWITCH RH

< REMOVAL AND INSTALLATION >

[LH&RH FRONT WINDOW ANTI-PINCH]

POWER WINDOW AND DOOR LOCK/UNLOCK SWITCH RH

Removal and Installation

INFOID:000000007253560

REMOVAL

1. Remove the front door grip cover. Refer to [INT-18, "Removal and Installation"](#).
2. Using suitable tool, remove the clip (A) from the door grip.

CAUTION:

Wrap a cloth around suitable tool to protect components from damage.

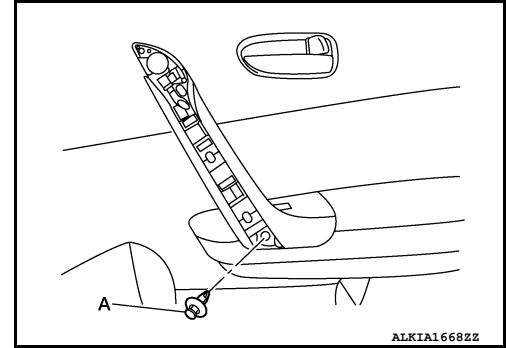

3. Using a suitable tool, release the metal clip and lift the power window and door lock/unlock switch (2) and switch finisher (1) as an assembly starting from the rear, pull upward to remove it from the front door finisher.

□: Metal clip

CAUTION:

Wrap a cloth around suitable tool to protect components from damage.

4. Disconnect the harness connector from the power window and door lock/unlock switch.
5. Release the pawls on each side to separate the switch finisher (1) from the power window and door lock/unlock switch (2).

○: Pawl

CAUTION:

Do not damage the pawl of the switch finisher.

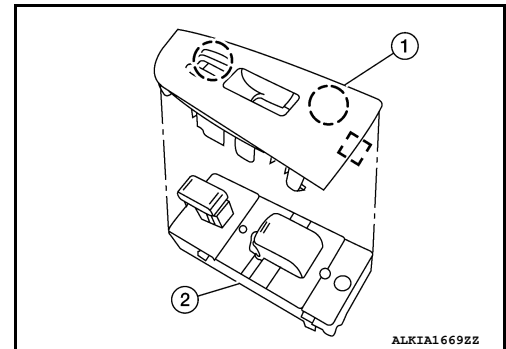

INSTALLATION

Installation is in the reverse order of removal.

NOTE:

Whenever the power window and door lock/unlock switch is disconnected from the harness connector, it is necessary to perform the Initialization procedure. Refer to [PWC-7, "ADDITIONAL SERVICE WHEN REPLACING CONTROL UNIT : Special Repair Requirement"](#).

REAR POWER WINDOW SWITCH

< REMOVAL AND INSTALLATION >

[LH&RH FRONT WINDOW ANTI-PINCH]

REAR POWER WINDOW SWITCH

Removal and Installation

INFOID:000000007253561

REMOVAL

1. Remove the rear door armrest finisher. Refer to [INT-21. "Removal and Installation"](#).
2. Using a suitable tool (A), release the pawls on each side to separate the switch finisher (1) from the rear power window switch (2).

○: Pawl

CAUTION:

Wrap a cloth around suitable tool to protect components from damage.

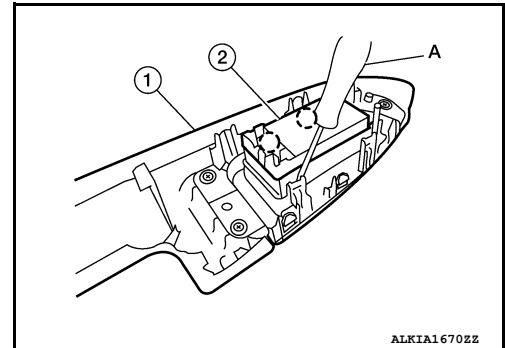

INSTALLATION

Installation is in the reverse order of removal.

A
B
C
D
E
F
G
H
I
J
L
M
N
O
P

PWC